



DG TAXUD

Business Process Description

ICS2

Date: 27/06/2017
Doc. Version: 0.5

Document Control Information

Settings	Value
Document Title:	Business Process Description
Project Title:	ICS2
Document Author:	Renata Pauliukaiyte, Stefan Wesp, Klemen Oven
Project Owner:	DG TAXUD ICS2 Project team
Solution Provider:	DG TAXUD ICS2 Project team
TAXUD Project Manager:	Guido De Jaegher
Doc. Version:	0.5
Sensitivity:	Basic
Date:	27/06/2017

Document Approver(s) and Reviewer(s):

NOTE: All Approvers are required. Records of each approver must be maintained. All Reviewers in the list are considered required unless explicitly listed as Optional.

Name	Role	Action	Date
	ECCG	Approve	
	TCG	Review	

Document history:

The Document Author is authorized to make the following types of changes to the document without requiring that the document be re-approved:

- Editorial, formatting, and spelling
- Clarification

To request a change to this document, contact the Document Author or Owner.

Changes to this document are summarized in the following table in reverse chronological order (latest version first).

Revision	Date	Created by	Short Description of Changes

TABLE OF CONTENTS

1 INTRODUCTION.....	6
1.1 Purpose.....	6
1.2 Scope	6
1.3 Target Audience.....	6
1.4 Structure of this document.....	6
1.5 Reference and applicable documents	7
1.5.1 Reference Documents.....	7
1.5.2 Applicable Documents	7
1.6 Abbreviations and Acronyms.....	7
1.7 Definitions.....	8
1.8 Business context	12
2 HIGH LEVEL END-TO-END PROCESS	14
2.1 Sub-processes	15
2.1.1 HLS001 - Register filing	15
2.1.2 HLS002 – Prepare ENS for risk analysis.....	19
2.1.3 HLS003 - Perform risk analysis	29
2.1.4 HLS004 - Process arrival of the means of transport.....	39
2.1.5 HLS005 – Process presentation and controls.....	45
2.1.6 HLS006 – Amend filing	50
2.1.7 HLS007 – Invalidate filing	55
2.2 Events	60
2.2.1 HLE01 – ENS filing received.....	60
2.2.2 HLE02 – Amendment of ENS filing received	60
2.2.3 HLE03 – Invalidation request received	60
2.2.4 HLE04 – 200 days timer expiry.....	60
2.2.5 HLE05 – ENS filing invalidated.....	60
2.2.6 HLE06 – Entry process completed	60
2.2.7 HLE07 – Arrival notification received.....	60
2.2.8 HLE08 – Arrival notification processed	60
2.2.9 HLE09 – Goods presented.....	61
2.2.10 HLE10 – Goods presented and controlled.....	61
3 MAIN ENTITIES & STATE TRANSITIONS.....	62
3.1 State transition diagram	62
4 ANNEX	64
4.1 ENS filing types	64

TABLE OF FIGURES

Figure 1: ICS2 Business context	12
Figure 2: ICS2 High level end-to-end process	14
Figure 3: HLS001 Register filing sub-process	16
Figure 4: HLS002 Prepare ENS for risk analysis sub-process.....	20
Figure 5: HLS003 Perform risk analysis sub-process.....	32
Figure 6: HLS004 Process arrival of the means of transport sub-process	40
Figure 7: HLS005 Process presentation and controls sub-process	46
Figure 8: HLS006 Amend filing sub-process.....	51
Figure 9: HLS007 Invalidate filing sub-process.....	56
Figure 10: Main entities.....	62
Figure 11: State transition example.....	62
Figure 12: State transition diagram	63

TABLE OF TABLES

Table 1: Reference documents	7
Table 2: Applicable documents.....	7
Table 3: Abbreviations and acronyms.....	8
Table 4: Definitions	11

1 INTRODUCTION

1.1 Purpose

This document provides the first iteration of the ICS2 Common functional system specifications (CFSS) package. This package will consist of three artefacts:

- Business process models and their descriptions (BPM level 3.5),
- IT component view (BPM level 4), and
- Message (information exchange) specifications.

From the processes description perspective, the basic principle is to draft the *business* processes and their descriptions at two levels, high level end-to-end process overview, and at the level of the sub-processes. These two levels will keep 'system agnostic' approach. For this reason a deviation from the DG TAXUD BPM methodology was made and a new BPM level 3.5 was introduced.

The second artefact of the CFSS will address the mapping of the business processes and data to the IT components and definition of the interfaces between those components. The third artefact will provide the specifications for the messages (information exchanges), including code list.

The aim of this document is to bring forward sufficient level of descriptions to support the understanding of the end-to-end business processes.

1.2 Scope

This document describes:

- the business context of the ICS2,
- the high level end-to-end business process,
- sub-processes, and
- main entities and their state transitions.

1.3 Target Audience

The intended audience for this document are the representatives of the Trade Contact Group.

1.4 Structure of this document

The present document contains the following chapters:

- **Chapter 1 – Introduction:** describes the scope and the objectives of the document;
- **Chapter 2 – High level end-to-end process:** describes the ICS2 high level end-to-end process and underlying sub-processes, their tasks and events;
- **Chapter 3 – Main entities and state transitions:** describes the entities and provides a state transition diagram;
- **Annex** – provides a list of the ENS filing types.

1.5 Reference and applicable documents

1.5.1 Reference Documents

Ref.	Title	Reference	Version	Date
R01	Regulation (EU) No 952/2013 of the European Parliament and of the Council of 9 October 2013 laying down the Union Customs Code			9/10/2013
R02	Commission Delegated Regulation (EU) 2015/2446 of 28 July 2015 supplementing Regulation (EU) No 952/2013 of the European Parliament and of the Council as regards detailed rules concerning certain provisions of the Union Customs Code			28/07/2015
R03	Commission Implementing Regulation (EU) 2015/2447 of 24 November 2015 laying down detailed rules for implementing certain provisions of Regulation (EU) No 952/2013 of the European Parliament and of the Council laying down the Union Customs Code			24/11/2015

Table 1: Reference documents

1.5.2 Applicable Documents

Ref.	Title	Reference	Version	Date
A01				

Table 2: Applicable documents

1.6 Abbreviations and Acronyms

For a better understanding of the present document, the following table provides a list of the principal abbreviations and acronyms used.

Abbreviation/Acronym	Definition
AEO	Authorised Economic Operator
AWB	Air Waybill
BoL	Bill of Lading
CFSS	Common Functional System Specifications
COFE	Customs Office of First Entry
CRC	Common Risk Criteria
CRMS2	Customs Risk Management System 2
D.E.	Data Element
DNL	Do Not Load
ENS	Entry Summary Declaration
EO	Economic Operator

EORI	Economic Operator Registration and Identification
e-RA	e-Risk Analysis
EU	European Union
HAWB	House Air Waybill
HBoL	House Bill of Lading
HRCM	High Risk Cargo and Mail
ICS2	Import Control System 2
IMO	International Maritime Organization
IMS	Involved Member State
MAWB	Master Air Waybill
MBoL	Master Bill of Lading
MRN	Master Reference Number
MS	Member State
NVOCC	Non-Vessel Operating Common Carrier
PLACI	Pre-loading Air Cargo Information
Rfi	Request for Information
RfS	Request for Screening
RMS	Responsible Member State
TARIC	Integrated Tariff of European Union
UCC	Regulation (EU) No 952/2013 of the European Parliament and of the Council of 9 October 2013 laying down the Union Customs Code
UCC DA	Commission Delegated Regulation (EU) 2015/2446 of 28 July 2015 supplementing Regulation (EU) No 952/2013 of the European Parliament and of the Council as regards detailed rules concerning certain provisions of the Union Customs Code
ULK	Unique Linking Key

Table 3: Abbreviations and acronyms

1.7 Definitions

Term	Definition
Air pre-loading risk analysis	Air pre-loading risk analysis is a limited security risk analysis by the customs aimed to identify potential risk of (improvised) explosive device entering into the air cargo supply chain posing threat to the civil aviation (aka 'bomb-in-a-box' risk assessment).
Air waybill (AWB)	An air waybill (AWB) is a document issued by a carrier (or his agent) to acknowledge receipt of cargo for shipment. It is a contractual document between the shipper/consignor of goods and the carrier detailing the type, quantity and destination of the goods being carried. The air waybill also serves as a receipt of shipment when the goods are delivered at the contractually determined destination.
AEO-S	Authorised Economic Operator authorised for security and safety.
Bill of Lading (BoL)	A bill of lading (BoL) is a document issued by a carrier (or his agent) to acknowledge receipt of cargo for shipment. It is a contractual document between the shipper/consignor of goods and the carrier detailing the type, quantity and destination of the goods being carried. The bill of lading also serves as a receipt of shipment when the goods are delivered at the predetermined destination.

Carrier	<p>Carrier means in the context of entry, the person who brings the goods, or who assumes responsibility for the carriage of the goods, into the customs territory of the Union. However,</p> <p>(i) in the case of combined transportation, "carrier" means the person who operates the means of transport which, once brought into the customs territory of the Union, moves by itself as an active means of transport;</p> <p>(ii) in the case of maritime or air traffic under a vessel- sharing or contracting arrangement, "carrier" means the person who concludes a contract and issues a bill of lading or air waybill for the actual carriage of the goods into the customs territory of the Union.</p>
Complete ENS	Complete ENS means an ENS containing all required data particulars required by the legislation per specific mode of transport or business model. Complete ENS can be either represented by a full ENS filing, or all necessary partial ENS filings that together contain all required data particulars.
Do Not Load (DNL)	Do Not Load (DNL) is a notification communicated by the customs authority of the RMS to the person filing (and the carrier under certain conditions) that the goods concerned shall not be allowed to be loaded on the aircraft or vessel.
e-Screening	<p>Electronic screening of ENS data which means electronic verification/matching of ENS data made available to IMS against risk information and knowledge of that Member State and the relevant applicable common risk criteria, in order to contribute to the risk analysis carried out by RMS:</p> <p>a) In the context of air cargo security (pre-loading) the scope of e-screening is limited to the minimum data set and contribution to the applicable common risk criteria for aviation security specific threat ('bomb in a box');</p> <p>b) For the rest of the cases, the scope of e-screening is applicable to the available data and contribution to the applicable common risk criteria, primarily for security and safety purposes.</p>
Entry Summary Declaration (ENS)	Entry Summary Declaration (ENS) means the act whereby a person informs the customs authorities, in the prescribed form and manner and within a specific time-limit, that goods are to be brought into the customs territory of the Union.
ENS filing	ENS filing means either partial or full ENS data set required by the legislation per specific mode of transport or business model.
ENS lifecycle	The ENS lifecycle is a term used to reference to the end-to-end process of the ENS statuses, from its filing until the final state of presentation, and where relevant performance of customs controls.
Full risk analysis	Full customs security and safety risk analysis covers the entire scope of the customs security and safety risks as defined in the common EU guidelines on the implementation of the respective common risk criteria and standards (classified as EU RESTREINT).
Full ENS filing	A full ENS filing contains all required ENS particulars, as legally defined per mode of transport in UCC DA Annex B.

House air waybill (HAWB)	A house air waybill (HAWB) is a form of an air waybill that is issued by a freight forwarder or an agent to its customer.
House bill of lading (HBoL)	A house bill of lading (HBoL) is a form of a bill of lading that is issued by a Non-Vessel Operating Common Carrier (NVOCC) or by a freight forwarder to its customer.
House level ENS filing	This is a partial filing which contains information derived from a HAWB, a HBoL, or a Postal items declaration, depending on the mode of transport.
High Risk Cargo and Mail Screening (HRCM screening)	High Risk Cargo and Mail Screening (HRCM screening) is a notification communicated by the customs authority of the RMS to the person filing (and the carrier under certain conditions) that the goods concerned shall need to be screened as a high risk cargo and mail, in accordance with the point 6.7.3 of the Annex to Commission Decision C (2010) 774 of 13 April 2010, before being loaded on board of an aircraft bound to the customs territory of the Union.
Involved Member State (IMS)	<p>Involved Member State is a Member State which is obliged to contribute to the risk analysis process of the RMS, notably to check ENS data made available against its national knowledge (i.e. contribution to the risk analysis of the RMS via application of national risk relevant knowledge and relevant common risk criteria in the area of security and safety).</p> <p>An IMS is considered to be a MS that is referenced in the ENS data. In case of air-cargo pre-loading consignments, IMS is considered to be any of the Member States (excluding the RMS), regardless of whether they are directly referenced in the ENS data.</p>
Master Air Waybill (MAWB)	Master air waybill (MAWB) is a form of an air waybill that is issued by the carrier to its direct contractual party (customer).
Master Bill of lading (MBoL)	Master bill of lading (MBoL) is a form of a bill of lading that is issued by the carrier to its direct contractual party (customer).
Master level ENS filing	This is a partial filing which contains information derived from a MAWB or MBoL, depending on the mode of transport.
Master Reference Number (MRN)	Master Reference Number means the registration number allocated by the competent customs authority to declarations or notifications.
Person filing	Person filing means any person that submits to the customs authority ENS filing in its complete or partial content and other notifications in the prescribed form and manner. This person can be any person that issues bill of lading or air waybill in any form and can be either carrier, NVOCC, freight forwarder, or any person identified by the legal provisions obliged to submit required particulars of ENS to the customs and can include postal operator, consignee stipulated in the lowest bill of lading. Person filing also includes representative of any of the persons mentioned above that submits the ENS filing in its complete or partial content to the customs authority on behalf of the person that it is representing.
PLACI	PLACI refers to a specific type of partial ENS filing, which is mandatory required as the minimum dataset ('7+1') to be filed as soon as possible prior to loading of the goods onto the aircraft in a third country. It is limited to the air traffic only and covers all goods (i.e. general cargo, express consignments and postal consignments).

Request for Information (Rfi)	Request for Information (Rfi) is a notification communicated by the customs authority of the RMS to the person filing (and the carrier under certain conditions) requesting further information on the particulars of the ENS.
Postal item	<p>Postal items is indivisible mailable entity in respect of which a mail service contractor accepts an obligation to provide postal services (postal items are physically aggregated into the postal receptacle)</p> <p><i>NOTE 1: Indivisible relates here to treatment within the postal system: items should be handled and delivered as an integrated unit and not split into components within the postal system.</i></p> <p><i>NOTE 2: Mail items are often qualified according to size, weight, handling or other service characteristics. Examples include letter mail (items), parcel post (items), registered mail (items), etc. Where no such qualification is provided, item should be understood as encompassing any or all types of mail.</i></p>
Postal receptacle	<p>Postal receptacle is a physical device which can be used to contain or carry mail so as to assist in its handling or transportation as a unit.</p> <p><i>EXAMPLE: Mailbags, trays, wheeled containers (roller cages), pallet and pallet-based containers and airfreight containers (ULDs).</i></p>
Responsible Member state (RMS)	<p>Responsible Member State is a Member State that has the legal responsibility to ensure that risk analysis is carried out and finalized primarily for security and safety purposes i.e. responsible to make a decision in terms of necessary measures to be taken to mitigate identified risk (e.g. action by the EO, or customs control action at different points of the supply chain).</p> <p>The RMS is the MS of the known customs office of first entry (COFE) to which the ENS filing is addressed.</p>
Unique Linking Key (ULK)	<p>The Unique Linking Key (ULK) is an automatically generated identifier which is used to associate / link two or more related ENS filings with an objective to compose the complete ENS. The ULK identifier is composed of the relevant data contained in the prescribed ENS data elements, such as carrier's transport document number, carrier's EORI number, number of receptacle etc. The necessary data elements to be used to create the ULK identifier are prescribed for each mode of transport and / or business model separately, and only apply in the case where ENS can be lodged in two or more ENS filings.</p>

Table 4: Definitions

1.8 Business context

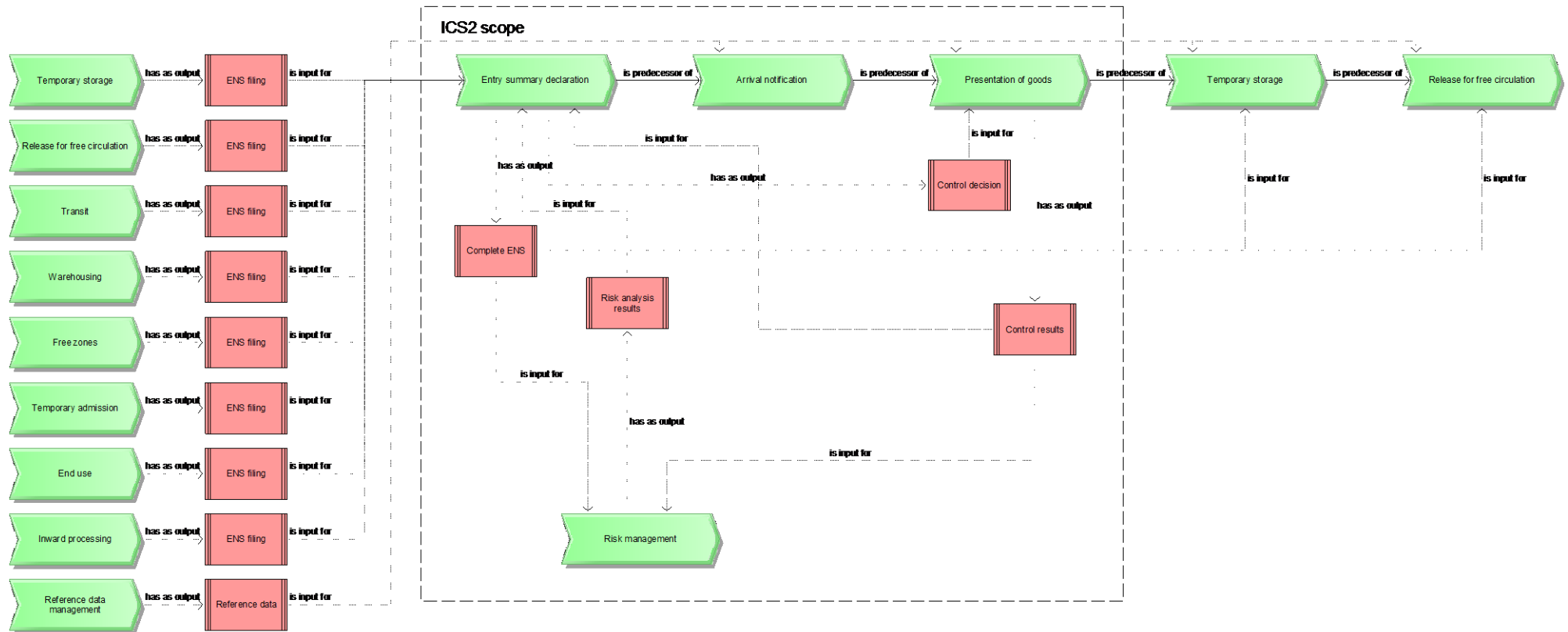

Figure 1: ICS2 Business context

The purpose of the above figure is to present ICS2 business context and depict different business interfaces between ICS2 components and other customs processes (see Figure 1).

Entry of the goods into the EU can be described as a 5 step process, consisting of the lodgement of the Entry summary declaration (ENS), notification of the arrival of the means of transport, presentation of goods, temporary storage and placing the goods under a customs procedure.

ICS2 business process scope covers 3 steps out of 5: lodgement of the ENS, notification of the arrival of the means of transport and presentation of goods. In addition, this process interacts with other customs processes in the global customs context.

First of all, the ENS filing can be lodged not only directly but also be an input from other customs processes. Art. 130 of UCC stipulates that ENS particulars can be combined with a declaration for temporary storage or a customs declaration for release for free circulation, transit, warehousing, free zones, temporary admission, end use and inward processing. These particulars then are to be extracted and submitted as input to ICS2 process in a form of an ENS filing.

Secondly, ICS2 process interacts with the reference data management process to obtain the necessary reference data, e.g. EORI number, AEO authorisation, TARIC, Customs Office list, other code lists.

ICS2 process provides inputs to other processes as well. Art. 145 (5) of UCC allows a reuse of the ENS data for temporary storage declaration. Art.144 of UCC DA permits using the ENS data for customs declaration for release for free circulation of the postal consignments. In these cases the complete ENS data will be re-used by the respective declarant for the relevant customs clearance processes.

Within the overall process of ICS2 there are interactions between the different components of the process: ENS data is provided to the risk management process as an input for the risk analysis, which returns the risk analysis results to be fed back into the lodgement of the ENS process. Next step is the control recommendation which is fed into the presentation of goods process from which control results are returned back to the lodgement of the ENS process and, in addition, provided to the risk management process.

2 HIGH LEVEL END-TO-END PROCESS

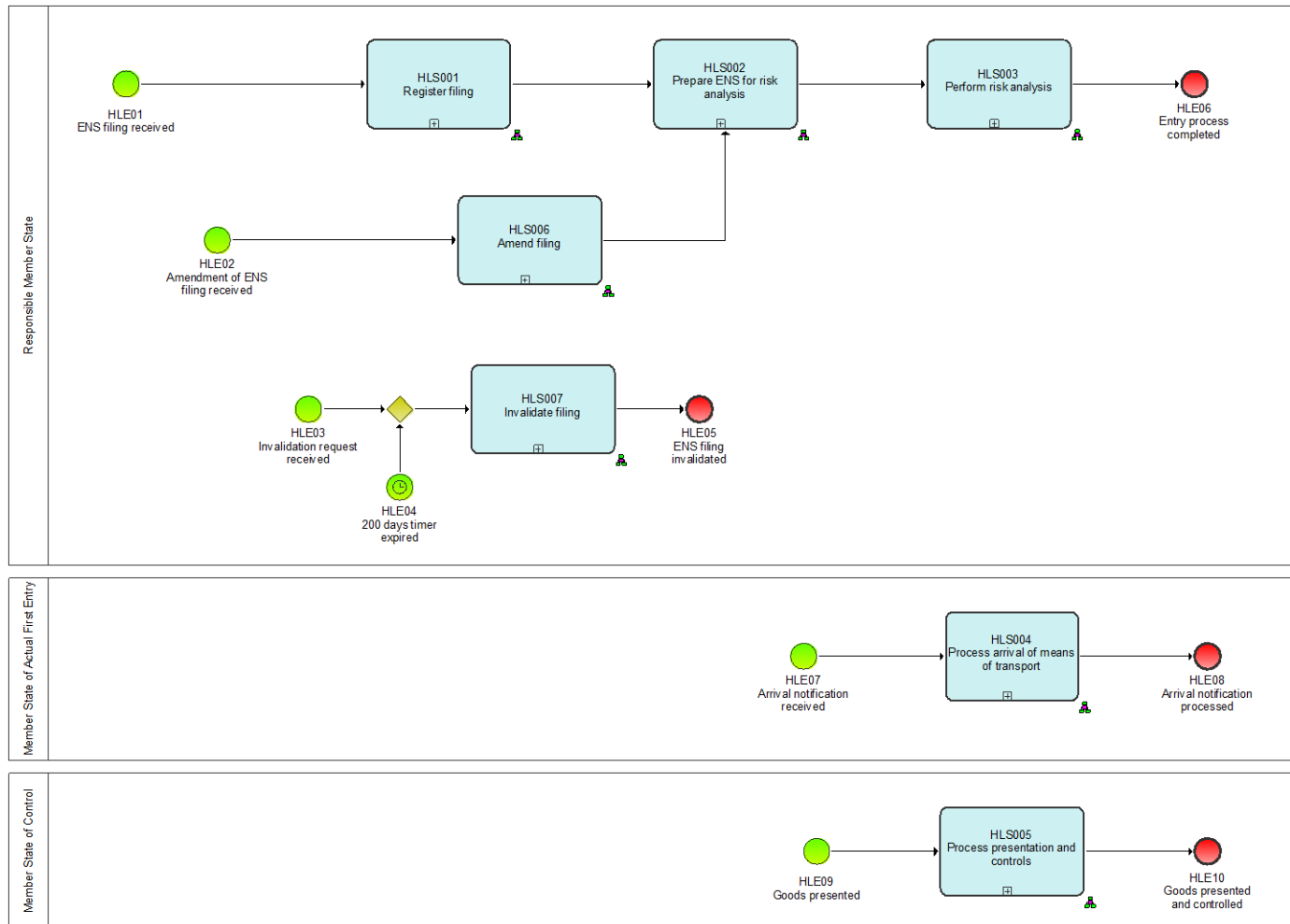

Figure 2: ICS2 High level end-to-end process

2.1 Sub-processes

2.1.1 HLS001 - Register filing

Register filing	HLS001
Organisation: National Customs Administration of the Responsible Member State	
Input: Received ENS filing	
<p>Description:</p> <p>The ENS filing is validated in an automated process. The validation comprises semantical and syntactical checks in order to ensure workability and data consistency as well as the identification of the kind of filing.</p> <p>If the ENS filing is not valid:</p> <ul style="list-style-type: none"> - it is rejected; - the person filing is notified of the rejection and of the errors that caused the rejection. <p>If the ENS filing is valid:</p> <ul style="list-style-type: none"> - It is registered; an MRN is generated and allocated to the received filing. - The person filing is notified of the registration and the MRN which was allocated to the filing. - When the carrier is different from the person filing and the carrier can be identified from the data derived from the filing, and the carrier has requested to be notified and is connected to the system he will also be notified. 	
<p>Output (Final situation):</p> <p>The filing is either rejected or registered.</p>	

2.1.1.1 Business Process Model

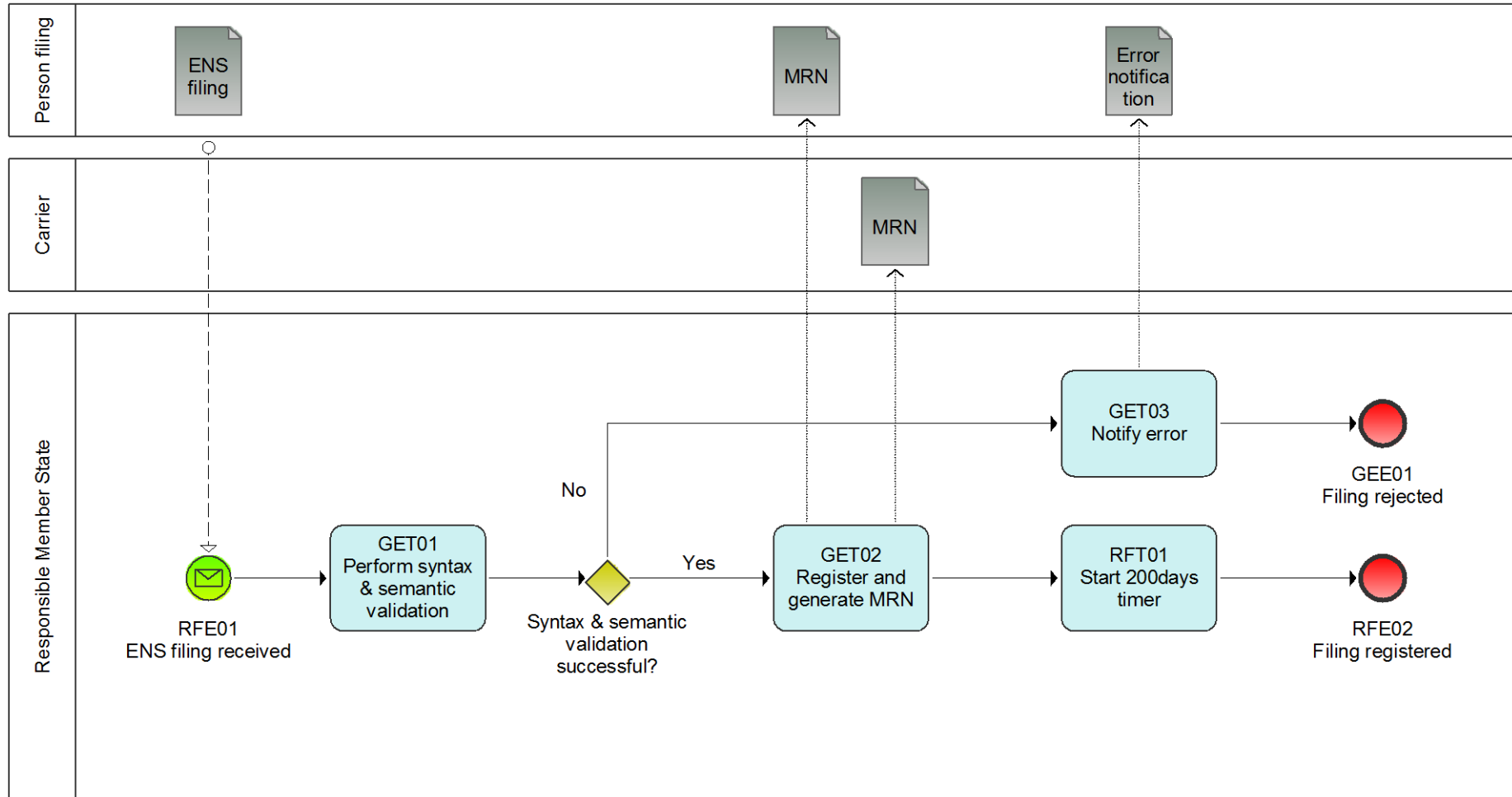

Figure 3: HLS001 Register filing sub-process

2.1.1.2 Tasks

2.1.1.2.1 GET01 - Perform syntax and semantic validation

Perform syntax and semantic validation	GET01
Organisation: National Customs Administration of Responsible Member State	
Input: ENS filing, Arrival notification, Amendment of ENS filing, Invalidation request	
Description: The input file is validated in an automated process. The validation comprises validation of message syntax, checks of the compliance with business rules and conditions as well as reference data. If the input file is not valid it is rejected; If the input file is valid it is further processed.	
Output (Final situation): The validation will have the following possible outcomes: <ul style="list-style-type: none"> - Successful; - Unsuccessful, in which case <ul style="list-style-type: none"> o the error description will be generated o the input file will obtain the state 'rejected' 	

2.1.1.2.2 GET03 - Notify error

Notify error	GET03
Organisation: National Customs Administration of Responsible Member State	
Input: Unsuccessful validation results - containing the error description	
Description: The file is not valid and rejected. The person filing is notified of the rejection and of the errors that caused the rejection.	
Output (Final situation): The notification of error is generated and sent to the person filing and the process ends.	

2.1.1.2.3 GET02 - Register and generate MRN

Register and generate MRN	GET02
Organisation: National Customs Administration of Responsible Member State	
Input: Valid ENS filing or Arrival notification	
Description: Valid file is registered; an MRN is generated and allocated to the received filing. The person filing is notified of the registration and the MRN which was allocated to the filing. When the carrier is different from the person filing and has requested to be notified and is connected to the system he will also be notified of the registration. In the case of received filing F25 (reference to the MAWB containing the list of underlying HAWB(s)), no additional MRN will be generated and the already generated MRN(s) for the previously received and related filing(s) F23 will be used. In the case of ENS filing containing minimum data-set for air cargo pre-loading processes, besides the above conditions that need to be met for notifying the carrier, the air carrier also needs to be identifiable from the data contained in the ENS filing: MAWB reference number.	
Output (Final situation): The file was registered and MRN has been generated. The person filing and the carrier (where applicable) has been notified. The file obtains the state 'registered'.	

2.1.1.2.4 RFT01 - Start 200 days timer

Start 200 days timer	RFT01
Organisation: National Customs Administration of Responsible Member State	

Input: Registered ENS filing
Description: The 200 days timer is started for the registered ENS filing. When the goods declared in the ENS filing do not arrive within 200 days the filing will be invalidated (legally not deemed being lodged).
Output (Final situation): 200 days countdown started.

2.1.1.3 Events

2.1.1.3.1 RFE01 - ENS filing received

ENS filing received	RFE01
Organisation: National Customs Administration of Responsible Member State	
A person lodges an ENS filing.	

2.1.1.3.2 GEE01 - Filing rejected

Filing rejected	GEE01
Organisation: National Customs Administration of Responsible Member State	
ENS filing is rejected.	

2.1.1.3.3 RFE02 - Filing registered

Filing registered	RFE02
Organisation: National Customs Administration of a Member State	
ENS filing is registered and, where applicable, MRN is generated.	

2.1.2 HLS002 – Prepare ENS for risk analysis

Prepare ENS for risk analysis	HLS002
Organisation: National Customs Administration of the Responsible Member State	
Input: Registered ENS filing	
<p>Description:</p> <p>This sub-process comprises the following actions on the registered ENS filing:</p> <ul style="list-style-type: none"> - Validation in terms of the relevant ENS's lifecycle status - Management of the timers for the completion of risk analysis - Extraction of the PLACI (i.e. 7+1 data elements), where applicable, and the triggering of the air pre-loading risk analysis - Linking of the related filings in order to compose a complete ENS - Triggering of the full risk analysis 	
<p>Output (Final situation):</p> <p>The registered ENS filing is either prepared for the air pre-loading risk analysis or the full risk analysis.</p>	

2.1.2.1 Business Process Model

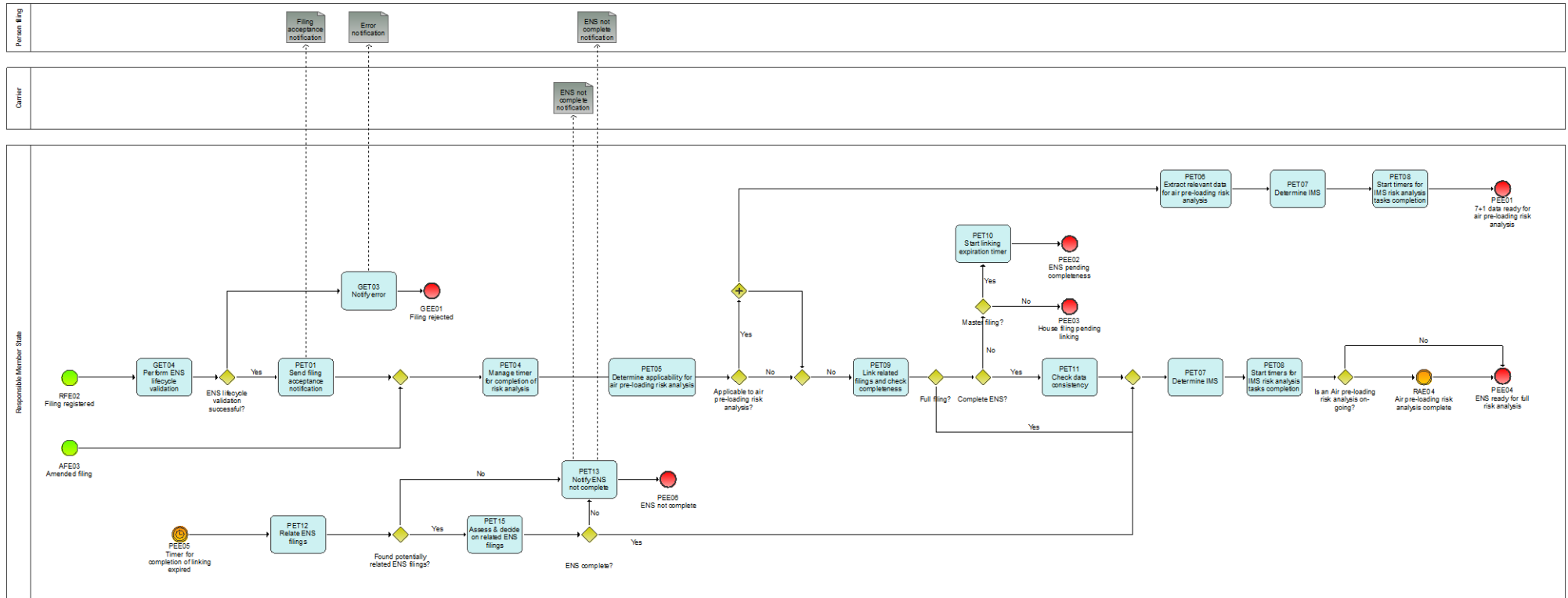

Figure 4: HLS002 Prepare ENS for risk analysis sub-process

2.1.2.2 Tasks

2.1.2.2.1 GET04 - Perform ENS-lifecycle validation

Perform ENS lifecycle validation	GET04
Organisation: National Customs Administration of Responsible Member State	
Input: ENS filing, Amendment of ENS filing, or Invalidation request	
<p>Description</p> <p>The ENS lifecycle validation checks</p> <ul style="list-style-type: none"> Whether the ENS filing is in the correct state regarding the ENS lifecycle's sequence of the process (E.g. whether an ENS filing refers to a journey of a means of transport which arrived already in the past, or the goods covered by the ENS filing were already presented to the customs and effectively the ENS cannot be filed for the same goods already presented, or ENS cannot be amended or invalidated) and; Whether relevant key data; in particular data elements which are used as a unique linking key are unique. In the case of indicated split shipments (i.e. ENS filing containing defined split shipment code indicator) where unique linking key data can be re-used for the remaining goods after the shipment was split, the ENS filing will be processed. <p>For an ENS amendment;</p> <ul style="list-style-type: none"> That the state of the original ENS filing is not 'presented' or at a state where, for example amendment of the ENS filing is not possible anymore (i.e. customs decided to perform controls, or trader notified by the customs that goods are to be controlled). That no particulars were amended which are not allowed to be amended. The person filing the amendment needs to be the declarant (D.Es. 3/17, 3/18) of the ENS filing referred to. <p>For an invalidation request;</p> <ul style="list-style-type: none"> The related ENS filing is required to be in a state prior to the state 'presented'. The person filing the invalidation request needs to be the declarant (D.Es. 3/17, 3/18) of the ENS filing referred to. <p>If the ENS lifecycle validation is successful, the input file obtains the state 'accepted' and the sub-process continues.</p> <p>If the ENS lifecycle validation fails the input file obtains the state 'rejected' and the sub-process ends.</p>	
<p>Output (Final situation):</p> <p>The state of the input file will either be changed to 'accepted' or 'rejected'.</p>	

2.1.2.2.2 GET03 - Notify error

Notify error	GET03
Organisation: National Customs Administration of Responsible Member State	
Input: Unsuccessful validation results - containing the error description	
<p>Description:</p> <p>The file is not valid and rejected. The person filing is notified of the rejection and of the errors that caused the rejection.</p>	
<p>Output (Final situation):</p> <p>The notification of error is generated and sent to the person filing and the process ends.</p>	

2.1.2.2.3 PET01 - Send filing acceptance notification

Send filing acceptance notification	PET01
Organisation: National Customs Administration of Responsible Member State	
Input: Successful validation results	
<p>Description</p> <p>The acceptance of the filing is notified to the person filing when this person has requested to be notified.</p>	

<p>Output (Final situation)</p> <p>The person filing was notified.</p>

2.1.2.2.4 PET04 – Manage timer for completion of risk analysis

Manage timer for completion of risk analysis	PET04
Organisation: National Customs Administration of Responsible Member State	
Input: Accepted ENS filing or Amended ENS filing	
<p>Description:</p> <p>It is determined whether a timer for the completion of full security and safety risk analysis is applicable to the ENS filing and when applicable the appropriate timer is selected and started.</p> <p>No timer is to be applied for ENS filings F14, F15, F16, F22, F23, F24, F25, F26, F32, F43 and F44. In the case of filings F23, F24, F25, F32 and F43 the timer is not applied due to the legal requirement to complete the risk analysis immediately, without prejudice to the suspension of such ‘time-limit’ in the case risk is identified or additional risk analysis needs to be carried out.</p> <p>For ENS filings F10, F11, F12, F13, F31 (in case of maritime transport) and F41 (in case of maritime transport) the timer is set to 24h upon reception of the ENS filing in cases of Article 105 (a) UCC-DA.</p> <p>For ENS filings F10, F11, F12, F13, F31 (in case of maritime transport) and F41 (in case of maritime transport) the timer is set to 4h upon reception of the ENS filing in cases of Article 105 (b) UCC-DA.</p> <p>For ENS filings F10, F11, F12, F13, F31 (in case of maritime transport) and F41 (in case of maritime transport) the timer is set to 2h upon reception of the ENS filing in cases of Article 105 (c) and (d) UCC-DA and cases of Article 109 UCC-DA.</p> <p>For ENS filings F20, F21, F27, F28, F29, F30, F42 the timer is set to 4h upon reception of the ENS filing in cases of Article 106 (2) (b) UCC-DA.</p> <p>For ENS filings F20, F21, F27, F28, F29, F30, F42 the timer is set to the remaining time until the expected (scheduled) time of arrival of the aircraft upon reception of the ENS filing in cases of Article 106 (2) (a) UCC-DA.</p> <p>For ENS filings F31 (in case of rail transport), F41 (in case of rail transport) and F51 the timer is set to 1h upon reception of the ENS filing in cases of Article 107 (a) UCC-DA.</p> <p>For ENS filings F31 (in case of rail transport), F41 (in case of rail transport) and F51 the timer is set to 2h upon reception of the ENS filing in cases of Article 107 (b) UCC-DA.</p> <p>For ENS filings F31 (in case of road transport), F41 (in case of road transport) and F50 the timer is set to 1h upon reception of the ENS filing.</p> <p>In case of Amended ENS filing, the timer for the original ENS filing will be stopped and no timer for the amended ENS filing will be started.</p>	
<p>Output (Final situation):</p> <p>The timer can either be started, stopped or not applicable.</p>	

2.1.2.2.5 PET05 – Determine applicability for air pre-loading risk analysis

Determine applicability for air pre-loading risk analysis	PET05
Organisation: National Customs Administration of a Responsible Member State	
Input: Accepted ENS filing or Amended ENS filing	
<p>Description:</p> <p>It is determined whether the ENS filing is subject to air pre-loading risk analysis.</p> <p>Only the following ENS filings are subject to air pre-loading risk analysis: F20, F23, F24, F26, F32 and F43.</p>	
<p>Output (Final situation):</p> <p>It is determined whether the ENS filing is subject to air pre-loading risk analysis.</p>	

2.1.2.2.6 PET06 – Extract relevant data for air pre-loading risk analysis

Extract relevant data for air pre-loading risk analysis	PET06
Organisation: National Customs Administration of a Responsible Member State	
Input: Accepted ENS filing or Amended ENS filing	

<p>Description:</p> <p>In the case a full ENS is filed at pre-loading phase (e.g. filing F20), only 7+1 data which are required by air pre-loading risk analysis are extracted from the filing.</p>
<p>Output (Final situation):</p> <p>Relevant extracted datasets for air pre-loading risk analysis are composed.</p>

2.1.2.2.7 PET07 – Determine IMS

Determine IMS	PET07
Organisation: National Customs Administration of a Responsible Member State	
Input: 7+1 data elements or ENS	
<p>Description:</p> <p>For air pre-loading risk analysis all Member States are considered to be Involved Member States.</p> <p>For the full risk analysis, the Involved Member States are identified through a set of relevant data elements contained in the ENS filing(s). Below are business rules i.e. data elements that should be considered per mode of transport and/or business model to identify an IMS:</p> <p>Sea and inland waterways (maritime cargo):</p> <ul style="list-style-type: none"> • Consignee country code master bill of lading level (D.E. 3/11, 3/12) • Consignee country code house bill of lading level (D.E. 3/13, 3/14) • Consignor country code house bill of lading, if country code equals the code of the EU MS (D.E. 3/5, 3/6) • Carrier country code (D.E. 3/32) • Buyer country code (D.E. 3/26, 3/27) • Seller country code, if the case country code equals the code of the EU MS (D.E. 3/24, 3/25) • Notify party country code master air waybill level (D.E. 3/33, 3/34) • Notify party country code house air waybill level (D.E. 3/35, 3/36) • Additional supply chain actor(s) identification (D.E. 3/37) • Person submitting the additional ENS particulars identification n° • Place of delivery code master air waybill level (D.E.5/10) • Place of delivery code house air waybill level (D.E. 5/11) • Subsequent customs office(-s) of entry (D.E. 5/13) • Countries of routing of means of transport (D.E. 5/19) • Countries of routing of the consignment codes (D.E. 5/20) • Place of unloading (D.E. 5/22) <p>General air cargo:</p> <ul style="list-style-type: none"> • Consignee country code master air waybill level (D.E. 3/11, 3/12) • Consignee country code house air waybill level (D.E. 3/13, 3/14) • Consignor country code house air waybill, if country code equals the code of the EU MS (D.E. 3/5, 3/6) • Carrier (D.E. 3/32) • Notify party country code master air waybill level (D.E. 3/33, 3/34) • Notify party country code house air waybill level (D.E. 3/35, 3/36) • [Additional supply chain actor(s) identification (D.E. 3/37)] • [Person submitting the additional ENS particulars identification n°] • Place of delivery code master air waybill level (D.E.5/10) • Place of delivery code house air waybill level (D.E. 5/11) • Subsequent customs office(-s) of entry (D.E. 5/13) • Countries of routing of means of transport (D.E. 5/19) 	

<ul style="list-style-type: none"> • Countries of routing of the consignment codes (D.E. 5/20) • Place of unloading (D.E. 5/22) <p>Express consignments:</p> <ul style="list-style-type: none"> • Consignee country code master air waybill level (D.E. 3/11, 3/12) • Consignee country code house air waybill level (D.E. 3/13, 3/14) • Consignor country code house air waybill, if country code equals the code of the EU MS (D.E. 3/5, 3/6) • Carrier (D.E. 3/32) • [Additional supply chain actor(s) identification (D.E. 3/37)] • [Person submitting the additional ENS particulars identification n°] • Subsequent customs office(-s) of entry (D.E. 5/13) • Countries of routing of means of transport (D.E. 5/19) • Countries of routing of the consignment codes (D.E. 5/20) • Place of unloading (D.E. 5/22) <p>Postal consignments:</p> <ul style="list-style-type: none"> • Consignee country code master air waybill level (D.E. 3/11, 3/12) • Consignee country code house air waybill level (D.E. 3/13, 3/14) • Carrier (D.E. 3/32) • [Additional supply chain actor(s) identification (D.E. 3/37)] • [Person submitting the additional ENS particulars identification n°] • Subsequent customs office(-s) of entry (D.E. 5/13) • Countries of routing of means of transport (D.E. 5/19) • Place of unloading (D.E. 5/22) <p>Road and Rail traffic:</p> <ul style="list-style-type: none"> • Consignee country code master bill of lading level (D.E. 3/11, 3/12) • Consignee country code house bill of lading level (D.E. 3/13, 3/14) • Consignor country code house bill of lading, if country code equals the code of the EU MS (D.E. 3/5, 3/6) • Carrier country code (D.E. 3/31, 3/32) • Buyer country code (D.E. 3/26, 3/27) • Seller country code, if the case country code equals the code of the EU MS (D.E. 3/24, 3/25) • Countries of routing of means of transport (D.E. 5/19) • Place of unloading (D.E. 5/22) • Nationality of active means of transport crossing the border (D.E. 7/15) and its Identity (D.E. 7/14) • Nationality of passive means of transport crossing the border (D.E. 7/17) and its Identity (D.E. 7/16)] <p>Output (Final situation): The Member States to be involved in an air pre-loading risk analysis or full risk analysis are determined.</p>
--

2.1.2.2.8 PET08 – Start timers for IMS risk analysis tasks completion

Start timers for IMS risk analysis tasks completion	PET08
Organisation: National Customs Administration of Responsible Member State	
Input: PLACI - 7+1 data elements or ENS	
Description: The appropriate timers' values for the completion of e-Screening on 7+1 data elements or on an ENS are calculated and started. Each IMS will have its own individual timer which indicates the time remaining to	

provide feedback to the RMS. The timer values need to be agreed as per scenario with regard to the overall timer for the RMS to complete the risk analysis.

Output (Final situation):

The timer values for all IMS are known and countdowns are activated.

2.1.2.2.9 PET09 – Link related filings and check completeness

Link related filings and check completeness	PET09
<p>Organisation: National Customs Administration of Responsible Member State</p>	
<p>Input: Accepted ENS filing or Amended ENS filing</p>	
<p>Description:</p> <p>In case of</p> <ul style="list-style-type: none"> - the filings F10, F11, F20, F27, F28, F29, F30, F31, F41, F50 and F51, the ENS will obtain the state 'ENS complete'; - the filings F12, F13, F21, F42 will obtain the state 'ENS complete' if all related house level filings have been lodged or the state 'ENS pending completeness' if any of the related house level filings are missing; - the filings F14, F15, F16, F22, F23, F24, F26, F32, F43, F44 will obtain the state 'Linked' if they have been linked to the related master level filing that has been also lodged or the state 'Pending linking' if the related master level filing is missing. <p>By using the unique linking key (ULK) defined for the given scenario it will be determined whether related ENS filings at master and house level already exist. It will be furthermore checked whether the ENS is already complete after related master and house level ENS filings were found.</p> <p>The linking of the filings should be done as per following possible combinations:</p> <ol style="list-style-type: none"> 1. Air (general cargo): <ul style="list-style-type: none"> ○ Partial filing(s) F23 are to be linked with the subsequent partial filing F25 (filing F25 triggers the linking process with the filing(s) F23). The linking of those two filings can be either done by referring in the F25 filing to the HAWB(s) which was/were declared in the F23 filing(s) or to the MRN(s) which were assigned to the F23 filing(s). ○ Partial filing(s) F22 are to be linked with the partial filing F21 both lodged pre-arrival (filing F21 triggers process of linking with the filing(s) F22). Three ENS data elements are to be used to form the unique linking key between two or more partial ENS filings submitted by different economic operators (i.e. carrier and freight forwarder submissions), notably the MAWB and HAWB (D.E. 2/3), declarant EORI number (D.E. 3/18) and the EORI number of the person who has to provide additional ENS particulars (D.E. 3/38). The filings F21 and F22 can be linked via the MAWB number and HAWB number(s) which will be the same in both filings and the EORI number in D.E. 3/38 in filing F21 which corresponds to the EORI number in D.E. 3/18 in filing(s) F22; or ○ Partial filing(s) F26 (lodged pre-loading) are to be linked with the partial filing F21 (lodged pre-arrival) (filing F21 triggers the process of linking with the filing(s) F26). The unique linking key will be identical as mentioned above. <p>The ENS for air cargo general is considered to be complete when all persons indicated in data element 3/38 of partial ENS filings (which relate to the same MAWB) have filed partial ENS and their filings were successfully linked with the related MAWB filing.</p> 2. Air (postal consignment): <ul style="list-style-type: none"> ○ Partial filing(s) F43 are to be linked with the subsequent partial filing F44 (filing F44 triggers the process of linking with the filing(s) F43). The filing F44 will refer to the postal item number used in filing F43 and relate the item to a given unique receptacle. ○ Partial filing(s) F43/F44 (already filed and linked at pre-loading) to be linked with the partial filing F42 (lodged-pre-arrival) (filing F42 triggers the process of linking with the filing(s) F43/F44 (two of them linked at pre-loading)). The filing F42 will be linked with the F43/44 data via the receptacle numbers which are declared in F42 and F44 (latter one already linked to F43). <p>The ENS for air (postal) is considered to be complete when all receptacles declared in the F42 filing are linked to F44 filings which were all successfully linked to F43 filings (item data) at an earlier stage.</p> 3. Sea and inland waterways (maritime cargo): 	

- Partial filing F13 to be linked with the partial filing(s) F16 (filing F13 triggers the process of linking with the filing(s) F16); or
- Partial filing F12 to be linked with the partial filing(s) F15 (filing F12 trigger the process of linking with the filing(s) F15); or
- Partial filing F12 to be linked with the partial filing(s) F14 and partial filing(s) F16 (filing F12 triggers the process of linking with the filing(s) F14);
- Partial filing F12 to be linked with the partial filing(s) F14 and partial filing(s) F15.

Four ENS data elements are to be used to form the linking key between two or more partial ENS filings submitted by economic operators (i.e. carrier and freight forwarder submissions), notably the MBoL (D.E. 2/3), declarant EORI number (D.E. 3/18), carrier identification number (D.E. 3/32) and EORI number of the person who has to provide additional ENS particulars (D.E. 3/38).

The filing F13 is linked to the partial filing(s) F16 by matching of the same straight bill of lading number (D.E. 2/3) in F13 and F16. Moreover, the declarant EORI number (D.E. 3/18) of filing F13 has to correspond to the carrier's identification number provided in D.E. 3/32 of the filing(s) F16 and the declarant identification number (D.E. 3/18) of filing F16 has to correspond to identification number of the person submitting the additional ENS particulars in filing F13.

The unique linking key to link a filing F12 to filings F14 and F15 is similar to the one mentioned above but the house bill of lading number is additionally referred to (D.E. 2/3) in filings F12 (carrier at master level) and filings F14 and F15. Lower house level filings are matched to upper house level filings by the identification number of the person submitting additional ENS particulars (D.E. 3/38) of the upper house level filing which has to correspond to the identification number of the declarant (D.E. 3/18) in the lower house level filing and the identification number of the carrier provided (D.E. 3/32) corresponds in both filings.

The composed ENS is considered to be complete when all persons indicated in data element 3/38 of partial ENS filings (which relate to the same MBoL) have filed partial ENS and they were successfully linked with the MBoL level filing (F12 or F13) .

Output (Final situation):

- the filings F10, F11, F20, F27, F28, F29, F30, F31, F41, F50 and F51, the ENS will obtain the state 'ENS complete';
- the filings F12, F13, F21, F42 will obtain the state 'ENS complete' if all related house level filings have been lodged or the state 'ENS pending completeness' if any of the related house level filings are missing;
- the filings F14, F15, F16, F22, F23, F24, F26, F32, F43, F44 will obtain the state 'Linked' if the related master level filing has been lodged or the state 'Pending linking' if the related master level filing is missing.

2.1.2.2.10 PET10 –Start linking expiration timer

Start linking expiration timer	PET10
Organisation: National Customs Administration of Responsible Member State	
Input: ENS in the state 'ENS pending completeness'	
<p>Description</p> <p>A partial master filing triggers the start of the timer for linking it with the related house level filings. The time allocated for the linking of partial filings should allow sufficient time for the completion of the risk analysis according to the legally set deadlines. Those deadlines depend on the given ENS scenario (i.e. transport mode and situations that determine time-limits – see Articles 105, 106, 107 UCC-DA).</p>	
<p>Output (Final situation):</p> <p>The timer for completing the ENS by linking house level filings with a partial master level filing is started.</p>	

2.1.2.2.11 PET11 - Check data consistency

Check data consistency	PET11
Organisation: National Customs Administration of Responsible Member State	
Input: Complete ENS	
Description	

Data consistency of linked partial ENS filings will be checked. This is done in order to ensure the appropriate ENS data consistency is provided for the risk analysis. The consistency check will take into account inconsistencies such as major weight and piece count discrepancies, changed actors, discrepancies in the referenced transport documents at the level of master and underlying house filings as well as differences in air pre-loading and pre-arrival filings (algorithms and reference data for this task to be defined).

Output (Final situation):

Data consistency check results, which will either be

- 'ok', or
- 'flagged', in the case the result is identified inconsistency.

2.1.2.2.12 PET12 – Relate ENS filings

Relate ENS filings	PET12
Organisation: National Customs Administration of Responsible Member State	
Input: ENS in the state 'ENS pending completeness' for which the linking expiration timer has expired	
Description This automated task tries to relate ENS filings by taking into account other data elements with common attributes in terms of their content (e.g. container numbers, shipping marks etc.) in addition to the ULK used for task PET09. In case the house level partial ENS filings which are potentially to be related to a given partial master level filing are found, those filings will be proposed for the final manual determination and linking.	
Output (Final situation): Related ENS filings found or not found.	

2.1.2.2.13 PET13 - Notify ENS not complete

Notify ENS not complete	PET13
Organisation: National Customs Administration of Responsible Member State	
Input: ENS in the state 'ENS pending completeness'	
Description The person filing and the carrier when different from the person filing and has requested to be informed and is connected to the customs system will be informed that the ENS is not complete. The notification will include the relevant information i.e. which ENS filings from which person expected to file are still missing.	
Output (Final situation): The person filing and where applicable the carrier are informed about the fact that no complete ENS was lodged so far.	

2.1.2.2.14 PET15 – Assess and decide on related ENS filings

Assess and decide on related ENS filings	PET15
Organisation: National Customs Administration of Responsible Member State	
Input: Related ENS filings	
Description: The related filings are to be assessed and a decision is to be taken whether the files are to be finally linked or not.	
Output (Final situation): Related ENS filings are either finally linked or not. When the ENS is complete after manual linking it obtains the state 'ENS complete'.	

2.1.2.3 Events

2.1.2.3.1 RFE02 - Filing registered

Filing registered	RFE02
Organisation: National Customs Administration of a Member State	
A registered ENS filing is available for preparation for risk analysis.	

2.1.2.3.2 GEE01 - Filing rejected

Filing rejected	GEE01
Organisation: National Customs Administration of Responsible Member State	
The ENS filing is rejected. The sub-process ends.	

2.1.2.3.3 AFE03 – Filing amended

Filing amended	AFE03
Organisation: National Customs Administration of Responsible Member State	
An amended ENS filing is available for preparation for risk analysis.	

2.1.2.3.4 PEE01 – 7+1 data is ready for air pre-loading risk analysis

7+1 data is ready for air pre-loading risk analysis	PEE01
Organisation: National Customs Administration of Responsible Member State	
PLACI (7+1) data is ready for air pre-loading risk analysis.	

2.1.2.3.5 PEE02 – ENS pending completeness

ENS pending completeness	PEE02
Organisation: National Customs Administration of Responsible Member State	
A partial master level ENS filing is not yet complete.	

2.1.2.3.6 PEE03 – House filing pending linking

House filing pending linking	PEE03
Organisation: National Customs Administration of Responsible Member State	
A partial house level ENS filing is not yet linked to a master level ENS filing.	

2.1.2.3.7 PEE04 - Ready for full risk analysis

ENS ready for full risk analysis	PEE04
Organisation: National Customs Administration of Responsible Member State	
When the input ENS filing was a full ENS filing or a complete ENS was successfully composed via the linking process, it obtains the state 'ready for full risk analysis'. The sub-process ends.	

2.1.2.3.8 PEE05 – Timer for completion of linking expired

Timer for completion of linking expired	PEE05
Organisation: National Customs Administration of Responsible Member State	
The timer for linking a partial master level ENS filing has expired. This triggers task PET12.	

2.1.2.3.9 PEE06 – ENS not complete

ENS not complete	PEE06
Organisation: National Customs Administration of Responsible Member State	
The ENS is not complete.	

2.1.3 HLS003 - Perform risk analysis

Perform risk analysis	HLS003
Organisation: National Customs Administration of the Responsible Member State	
Location : Addressed office of the Responsible Member State	
Input: Registered ENS filing which is prepared for risk analysis	
<p>Description:</p> <p>Risk analysis process is triggered at the moment when the ENS status is complete (i.e. successful linking process of partial ENS filings or complete ENS filing).</p> <p>The Member States to be involved are identified and the registered filing is made available to all the relevant Member States for e-screening performance (i.e. those identified in the ENS data-set that are in the supply chain of the given consignment(s) for full security and safety risk analysis, and to all MS for air cargo preloading security risk analysis).</p> <p>Simultaneously, the e-screening is also performed by the Responsible Member State, as part of its overall electronic risk analysis process. Results of the e-screening from involved Member States are collected, allocated and made available to the Responsible Member State before that Member State completes the risk analysis process. Depending on the results of overall risk analysis the following action is to be taken:</p> <ol style="list-style-type: none"> 1. When no hit was indicated by automated risk analysis of the Responsible Member State, and there is no confirmed hit from the involved Member State(s), and there is no data quality or data inconsistency flag, there is nothing further to do. 2. When a hit was indicated by automated risk analysis, or a data quality or data inconsistency was flagged (or confirmed hit received as a result of e-screening done by involved Member State(s)), it is followed by the manual review / risk mitigation of the validity of the machine-identified hit or flag by a risk analysis official of the Responsible Member State. In the case of air (general cargo, postal consignments, express consignments) when at the phase of pre-loading risk analysis the outcome resulted in confirmation of other type of security and safety risk (not air cargo security), this result is taken into account in the further process of risk analysis): <ol style="list-style-type: none"> a. The hit of automated risk analysis is identified after the manual review as not valid i.e. 'false positive hit'. The hit is downgraded to no hit, recorded as 'false positive' and no measures to be taken, b. The hit of the automated risk analysis or the flag produced due to the data quality or data inconsistency issue, prompts the risk analysis official of Responsible Member State to receive improved data quality or to gather further additional information in order to decide on further risk mitigation measure to be taken (this includes also potential results and request made by the involved Member State(s)' e-screening). Responsible Member State requests for more information from the person filing and informing the carrier when the carrier is different from the person filing about this request, and the carrier can be identified from the data derived from the filing and the carrier has requested to be notified and is connected to the system (Request for Information (RfI) referral to be sent). <ol style="list-style-type: none"> i. Person filing (partial) ENS makes available necessary additional information, either through amendment of the original filing (i.e. in the case of data quality/inconsistency issue), or via structured communication as a reply to the request of customs (following the hit of the electronic risk analysis system which prompted such request), or making data available through the access by risk analysis official to the filing person's proprietary system ii. If the additional information is provided through the amendment of the original (partial) ENS filing, the automated risk analysis process is re-initiated after the amendment is registered iii. If the additional information is provided through the structured communication or via access to the proprietary system of the filing person, the risk analysis official performs additional review based on the information received in order to decide on the presence or absence of the risk. iv. Risk analysis official of the Responsible Member State may need in some circumstances to request for more risk mitigation information also involved Member State(s). Once the request is made, the official(s) of the involved Member State(s) should provide back the necessary requested information with the 	

- minimum delay (varying and depending on the available time-limits to perform/conclude risk analysis) to allow responsible Member state to carry out necessary review / risk mitigation and decision making process as part of the overall risk analysis
- v. the result of this additional review may be that the security and safety risk is not confirmed, in that case the result is recorded and the process ends, or
 - vi. the risk is confirmed and further risk mitigation measure is necessary. In this case risk analysis official decides for risk mitigation measure as per point 3. below
3. Following the process in the point 2. above, or independently, the hit of the automated risk analysis indicates suspicion of presence of a security and safety risk (or air cargo specific risk in the case of air cargo pre-loading risk analysis), the Responsible Member State risk analysis official confirms the level of risk and decides on the risk mitigation action to be taken (this includes also potential result from e-screening performed by the involved Member State that give rise to this level of suspicion):
- a. Risk identified is of a serious security and safety threat that requires immediate action to prohibit loading of goods onto the aircraft or vessel. This scenario is only applicable for the air cargo and for the specific cases of maritime containerised cargo (Article 105 (a) of the Commission Delegated Regulation (EU) 2015/2446). A notification for 'Do Not Load' (DNL) (i.e. 'order' to prevent goods to be loaded onto the aircraft or vessel) is communicated to the person filing and to the carrier when the carrier is different from the person filing, and the carrier is connected to the system. The person filing (partial) ENS notifies the Responsible Member States with the confirmation that the goods were removed from the supply chain and not loaded onto the aircraft or vessel.
 - b. Risk identified poses a threat of such a nature that it requires immediate intervention at the Office of First Entry according to Art. 186 (6) of the Commission Implementing Regulation (EU) 2015/2447. A decision is taken to perform necessary controls at the office of first entry (this implies also goods that would normally remain on board of the means of transport at their arrival to the customs office of first entry)
 - c. Risk identified does not pose such a serious threat to the security and safety to warrant an immediate control action at the customs office of first entry. A decision is taken to pass the results of risk analysis and information about the most appropriate place where a control action should be carried out to all involved Member States, as per Art. 186 (7) of Regulation (EU) 2015/2447 (i.e. customs offices potentially concerned by the movement of the goods, e.g. subsequent customs office(s) of entry (where the goods are unloaded first), customs office(s) responsible for control at the place where goods are presented subsequent to the place of first unloading (e.g. destination feeder seaport) or of final destination indicated in the ENS data-set)

It should be noted that the measures mentioned above are not necessarily to be taken alternatively and can also be applied cumulatively when the risk could not be mitigated by a previously taken measure, e.g. when the additional information requested is not considered to be sufficient to mitigate the suspicion a DNL decision can be the ultimate measure.

A risk analysis result code is to be assigned which depends on the identified level of threat which will influence the decision on whether the goods will be subject to controls and where the controls will take place (COFE or at a later stage like subsequent customs office of entry (first unloading location) or place where goods are presented subsequent to the place of first unloading, or customs office of destination)

In the case of DNL decision, the Responsible Member State informs all Member States about the case applying Article 46 UCC channels. Responsible Member State and involved Member States will adjust and apply within the minimum delay common risk criteria in order to identify high risk consignments with similar characteristics.

Output (Final situation):

Risk analysis was performed and measures to be taken were decided and executed.

2.1.3.1 Business Process Model

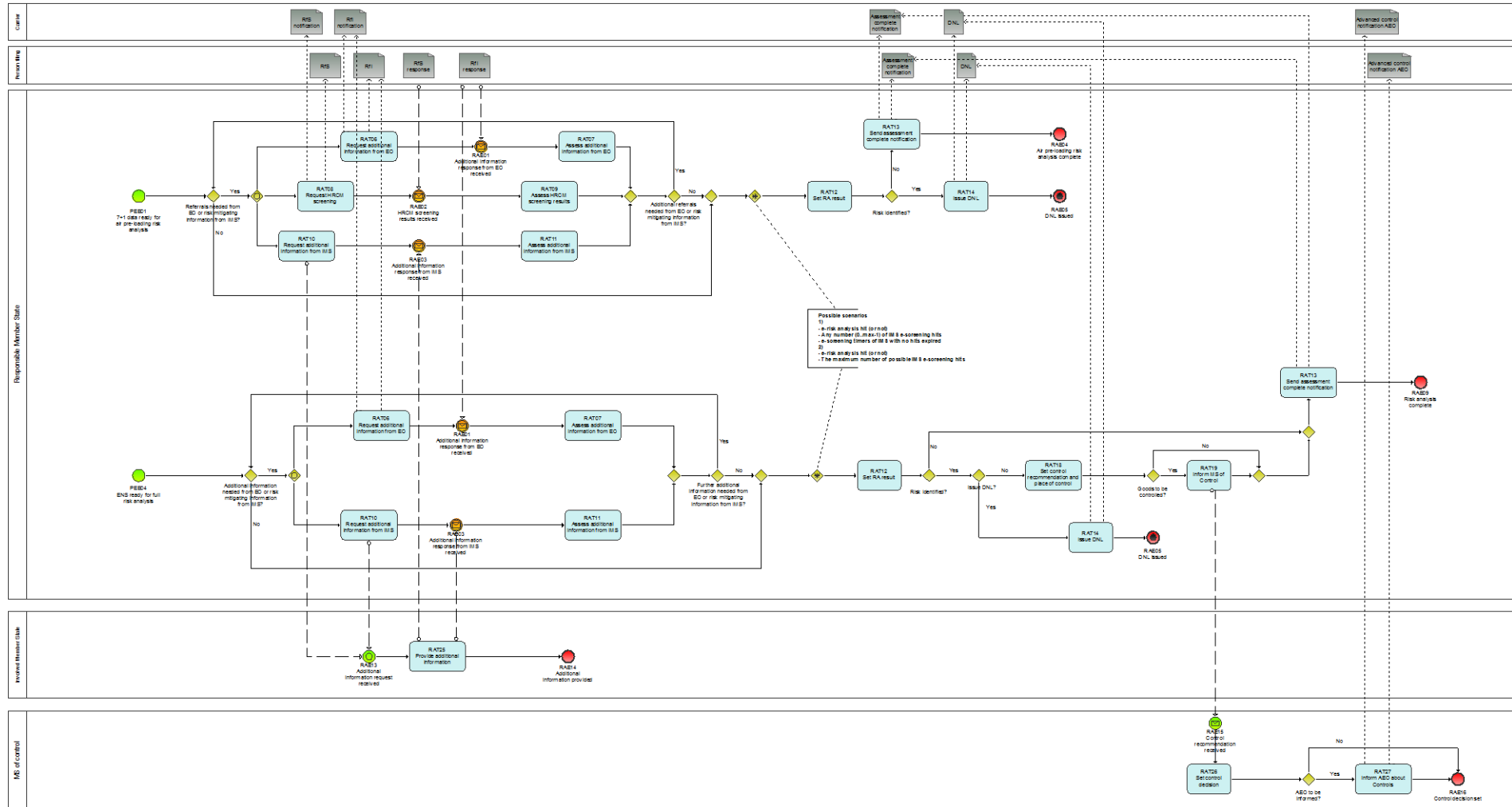

Figure 5: HLS003 Perform risk analysis sub-process

2.1.3.2 Tasks

2.1.3.2.1 RAT06 - Request additional information from EO

Request additional information from EO	RAT06
Organisation: National Customs Administration of Responsible Member State	
Input: Request for additional information (Rfi) from the economic operator concerned	
<p>Description:</p> <p>The Rfi in the context of air cargo pre-loading risk analysis process can either concern:</p> <ul style="list-style-type: none"> - the need for additional information / documents to be sent by the person filing (i.e. person to which the request is sent) - the need to improve the data quality of specific date element(s) through amendments of ENS filing, or - the type of screening (if any) that has already been performed on the consignment. <p>The Rfi in the context of full risk analysis process can either concern:</p> <ul style="list-style-type: none"> - the need for additional information/ documents to be sent by the person filing (i.e. person to which the request is sent), or - the need to improve the data quality of specific date element(s) through amendments of ENS filing. <p>In the case the customs risk analyst decided that the Rfi is necessary, the request is communicated to the economic operator concerned.</p> <p>The request is sent to the person filing and to the carrier when the carrier is known, connected to the system and has requested to be informed.</p>	
<p>Output (Final situation):</p> <p>It can either be</p> <ul style="list-style-type: none"> - request for additional information, or - request to amend an ENS filing 	

2.1.3.2.2 RAT07 - Assess additional information from EO

Assess additional information from EO	RAT07
Organisation: National Customs Administration of Responsible Member State	
Input: Additional information received from the EO	
<p>Description:</p> <p>The customs risk analyst performs additional assessment based on the information received from the EO. In the case of air pre-loading risk analysis, the outcome of the assessment can be the necessity for a HRCM screening to be performed.</p>	
<p>Output (Final situation):</p> <p>It can either be additional referrals are needed, or not.</p>	

2.1.3.2.3 RAT08 - Request HRCM screening

Request HRCM screening	RAT08
Organisation: National Customs Administration of Responsible Member State	
Input: Request for HRCM-screening (RfS)	
<p>Description:</p> <p>In the case the customs risk analyst decided that HRCM screening is necessary, the request is communicated to the person filing and to the carrier, provided the carrier is known, connected to the system and has requested to be informed.</p> <p>HRCM screening can be also requested in a combination with, or after the request for additional information to the EO or IMS were communicated and the assessment of additional information leads to the need for the HRCM (escalation measure). Request for HRCM screening may also be triggered while the Rfi request is still in pending status, and the customs analyst decides nevertheless to escalate the risk mitigation measure by requesting HRCM screening (this is in particular valid in the case when the EO does not provide necessary</p>	

additional information or improve data quality via the amendment of the ENS filing, in a 'reasonable time-frame').

Output (final situation): The request for HRMC screening is communicated to the person filing and where applicable to the carrier.

2.1.3.2.4 RAT09 - Assess HRCM screening results

Assess HRCM screening results	RAT09
Organisation: National Customs Administration of Responsible Member State	
Input: HRCM screening results	
Description The customs risk analyst assesses the available results of the HRCM screening.	
Output (Final situation): HRCM screening results have been assessed.	

2.1.3.2.5 RAT10 - Request additional information from IMS

Request additional information from IMS	RAT10
Organisation: National Customs Administration of Responsible Member State	
Input: Request for further information from the Involved Member State(s)	
Description: In the case the customs risk analyst decided that additional risk mitigation information is necessary to be obtained from a specific Involved Member State, the request is communicated to that Member State.	
Output (Final situation): Additional risk mitigation information request communicated to the specific Involved Member State.	

2.1.3.2.6 RAT11 - Assess additional information from IMS

Assess additional information from IMS	RAT11
Organisation: National Customs Administration of Responsible Member State	
Input: Additional information received from the IMS	
Description: The customs risk analyst assesses the additional information received from the IMS.	
Output (Final situation): Customs risk analysts completes the assessment.	

2.1.3.2.7 RAT12 - Set RA result

Set RA result	RAT12
Organisation: National Customs Administration of Responsible Member State	
Input: will either be <ul style="list-style-type: none"> - no hit from e-risk analysis and e-screening, or - any hit, along with the results of the assessment of the risk analyst 	
Description: In case of no hit, the risk analysis result will be automatically set to 'No risk'. Result of the confirmed e-risk analysis (through manual risk assessment, and supported where necessary by additional information provided by the EO and/or involved Member State) and / or of the confirmed e-screening process completed and communicated by the Involved Member State is transformed into the final risk analysis result by the risk analyst. The risk result can be: <ul style="list-style-type: none"> - No risk - Risk identified - Risk identified - DNL (where applicable) 	
Output (Final situation):	

The risk result can be:

- No risk, ENS will obtain the state: 'Full RA complete - No risk'
- Risk identified, ENS will obtain the state: 'Full RA complete - Risk identified'
- Risk identified - DNL (where applicable), ENS will obtain the state: 'Full RA complete - DNL'

2.1.3.2.8 RAT13 - Send assessment complete notification

Send assessment complete notification	RAT13
Organisation: National Customs Administration of Responsible Member State	
Input: Risk analysis result	
Description In case the risk analysis result was other than 'Risk identified - DNL', the person filing will be notified about the completion of the risk analysis. Where the carrier is known, different from the person filing, connected to the system and has requested to be informed he will be also informed in parallel.	
Output: The person filing is informed about the completion of risk analysis and where applicable the carrier too.	

2.1.3.2.9 RAT14 – Issue DNL

Issue DNL	RAT14
Organisation: National Customs Administration of Responsible Member State	
Input: Risk analysis result	
Description: The Risk Analyst confirms the issuance / communication of DNL notification to the person filing. Where the carrier is known, different from the person filing and connected to the system he will be also informed in parallel about the DNL issued. Where the carrier is not known or known and not connected to the system the person filing will have to communicate the DNL decision to the carrier. This is only applicable to the air pre-loading and containerised deep-sea traffic risk analysis cases and where the timer for completion of the risk analysis has not yet expired.	
Output (Final situation): DNL issued / communicated. The sub-process ends.	

2.1.3.2.10 RAT18 - Set control recommendation and place of control

Set control recommendation and place of control	RAT18
Organisation: National Customs Administration of Responsible Member State	
Input: Risk analysis result	
Description: This concerns the cases where a risk other than DNL was identified. Risk analyst sets, on the basis of the final risk analysis result, the control decision which includes recommended type of control and place of control. This decision may be based on the earlier communication and co-ordination between the Responsible Member State and Involved Member State concerned.	
Output (Final situation): Control recommendation is set.	

2.1.3.2.11 RAT19 - Inform Member State of Control

Inform Member State of Control	RAT19
Organisation: National Customs Administration of Responsible Member State	
Input: Control recommendation	
Description:	

Communication on the control decision which includes recommended type of control and place of control is sent to the Member State of control. This decision may be based on the earlier communication and co-ordination between the Responsible Member State and involved Member State concerned.

Output (Final situation):

Member State of Control was informed.

2.1.3.2.12 RAT25 - Provide additional information

Provide additional information	RAT25
Organisation: National Customs Administration of Involved Member State	
Input: Received request for additional information	
Description: The customs risk analyst of the Involved Member State communicates the additional risk mitigation information to the Responsible Member State.	
Output (Final situation): Additional risk mitigation information as requested by the RMS is communicated.	

2.1.3.2.13 RAT26 - Set control decision

Set control decision	RAT26
Organisation: National Customs Administration of Member State of control	
Input: Received information about control recommendation from RMS	
Description The Member State of control decides on the type of control to be performed based on the recommendation received from RMS.	
Output (Final situation): Control decision is set.	

2.1.3.2.14 RAT27 - Inform AEO of Controls

Inform AEO of Controls	RAT27
Organisation: National Customs Administration of Responsible Member State	
Input: Control decision	
Description In the case the controls are to be carried out on the goods which were declared by an AEO certified for security, risk analysts can decide to communicate to that AEO an advanced control notification, under the condition that customs controls will not be jeopardised. Where the carrier is different from the person filing and holds also an AEO status for security and is connected to the system he is also informed in advance about the control provided the person filing was decided to be informed.	
Output: The person filing is informed about the decided control and where applicable the carrier too.	

2.1.3.3 Events

2.1.3.3.1 PEE01 – 7+1 data ready for air pre-loading risk analysis

7+1 data ready for air pre-loading risk analysis	PEE01
Organisation: National Customs Administration of Responsible Member State	
Description: PLACI (7+1 data elements) will considered to be ready for air pre-loading risk analysis when: <ul style="list-style-type: none"> - An accepted filing F23 or F32 is available, IMS were determined and the timers for those IMS were started - The 7+1 data elements were extracted from an accepted filing F20, F26, F28 or F43, IMS were determined and the timers for those IMS were started 	

2.1.3.3.2 PEE04 - ENS Ready for full risk analysis

ENS Ready for full risk analysis	PEE04
---	--------------

Organisation: National Customs Administration of Responsible Member State
Description: An ENS will be considered ready for full risk analysis as soon as one of the following occurs: <ul style="list-style-type: none"> - A full ENS filing is registered; - All partial ENS filings are successfully linked; - All partial ENS filings are manually related; - The risk analysis process will be manually triggered to run on the master level filing only, or on the enhanced master level filing, which has been partially related to house level filings (but some are missing).

2.1.3.3.3 RAE01 – Additional information response from EO received

Additional information response from EO received	RAE01
Organisation: National Customs Administration of Responsible Member State	
Description: The EO has answered to a request for additional information.	

2.1.3.3.4 RAE02 – HRCM-screening results received

HRCM-screening results received	RAE02
Organisation: National Customs Administration of the Responsible Member State	
Description: The results of the HRCM-screening requested by the RMS were received from the EO.	

2.1.3.3.5 RAE03 – Additional information response from an IMS received

Additional information response from IMS received	RAE03
Organisation: National Customs Administration of the Responsible Member State	
Description: Response on request for additional information was received from IMS.	

2.1.3.3.6 RAE04 – Air pre-loading risk analysis complete

Air pre-loading risk analysis complete	RAE04
Organisation: National Customs Administration of Responsible Member State	
Description: The air pre-loading risk analysis is complete. The results leading into this event can be the following: <ul style="list-style-type: none"> • A risk was identified but not of such a serious threat that DNL would be justified (the identified risk will be followed up at full risk analysis); • No risk was identified. 	

2.1.3.3.7 RAE05 – DNL issued

DNL issued	RAE05
Organisation: National Customs Administration of Responsible Member State	
Description: The completion of air pre-loading risk analysis identified such a serious threat to the air cargo security that a DNL (Do Not Load) notification needs to be issued.	

2.1.3.3.8 RAE09 – Risk analysis complete

Risk analysis complete	RAE09
Organisation: National Customs Administration of Responsible Member State	
Description: The full risk analysis is complete.	

2.1.3.3.9 RAE13 – Additional information request received

Additional information request received	RAE13
Organisation: National Customs Administration of Involved Member State	
Description: A request for additional information from the RMS was received by the IMS.	

2.1.3.3.10 RAE14 – Additional information provided

Additional information provided	RAE14
Organisation: National Customs Administration of a Involved Member State	
Description: The requested additional information by the RMS was provided from the Involved Member State.	

2.1.3.3.11 RAE15 – Control recommendation received

Control recommendation received	RAE15
Organisation: National Customs Administration of a Member State of control	
Description: The Member State of control received a control recommendation from the RMS.	

2.1.3.3.12 RAE16 – Control decision set

Control decision set	RAE16
Organisation: National Customs Administration of a Member State of control	
Description: The Member State of control set its control decision.	

2.1.4 HLS004 - Process arrival of the means of transport

Process arrival of the means of transport	HLS004
Organisation: National Customs Administration of the Member State of actual first entry	
Input: Arrival notification	
Description: In case of transport by aircraft or vessel an arrival notification for the means of transport is to be lodged by the economic operator. The arrival notification identifies the Member State of actual first entry and triggers controls on goods which were identified being a risk requiring a control at the first point of entry in the EU.	
Output (Final situation): The arrival of the means of transport is recorded and the relevant ENSs which are subject to control measures at the customs office of first entry are identified.	

2.1.4.1 Business Process Model

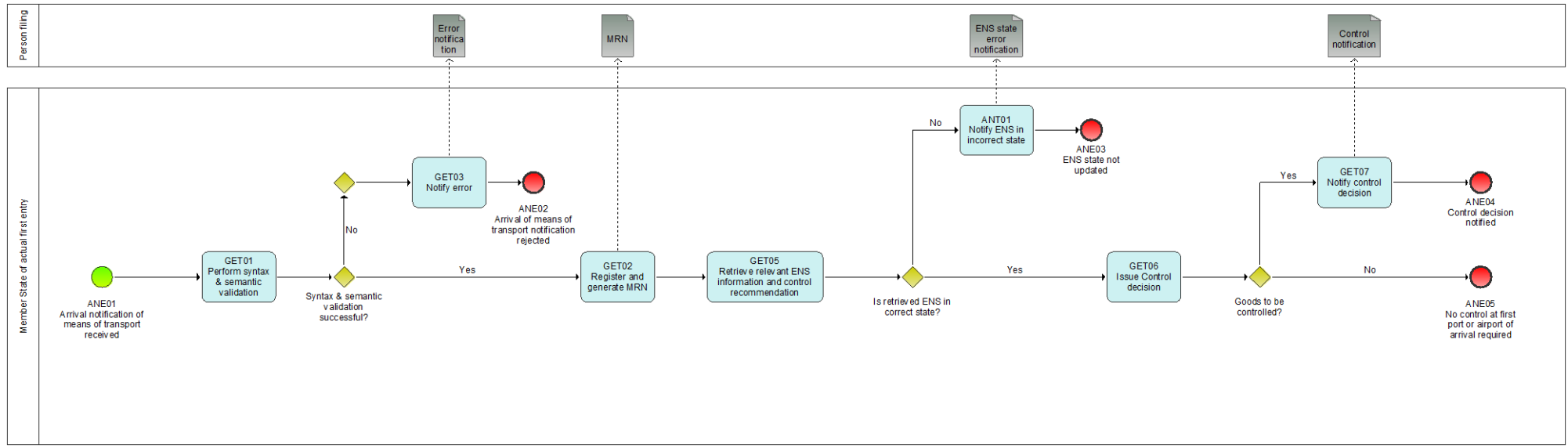

Figure 6: HLS004 Process arrival of the means of transport sub-process

2.1.4.2 Tasks

2.1.4.2.1 GET01 - Perform syntax and semantic validation

Perform syntax and semantic validation	GET01
Organisation: National Customs Administration of Responsible Member State	
Input: ENS filing, Arrival notification, Amendment of ENS filing, Invalidation request	
Description: The input file is validated in an automated process. The validation comprises validation of message syntax, checks of the compliance with business rules and conditions as well as reference data. If the input file is not valid it is rejected; If the input file is valid it is further processed.	
Output (Final situation): The validation will have the following possible outcomes: <ul style="list-style-type: none"> - Successful; - Unsuccessful, in which case <ul style="list-style-type: none"> o the error description will be generated o the input file will obtain the state 'rejected' 	

2.1.4.2.2 GET03 – Notify error

Notify error	GET03
Organisation: National Customs Administration of Responsible Member State	
Input: Unsuccessful validation results – containing the error description	
Description: The file is not valid and rejected. The person filing is notified of the rejection and of the errors that caused the rejection.	
Output (Final situation): The notification of error is generated and sent to the person filing and the process ends.	

2.1.4.2.3 GET02 – Register and generate MRN

Register and generate MRN	GET02
Organisation: National Customs Administration of Responsible Member State	
Input: Valid ENS filing or Arrival notification	
Description: Valid file is registered; an MRN is generated and allocated to the received filing. The person filing is notified of the registration and the MRN which was allocated to the filing. When the carrier is different from the person filing and has requested to be notified and is connected to the system he will also be notified of the registration. In the case of received filing F25 (reference to the MAWB containing the list of underlying HAWB(s)), no additional MRN will be generated and the already generated MRN(s) for the previously received and related filing(s) F23 will be used. In the case of ENS filing containing minimum data-set for air cargo pre-loading processes, besides the above conditions that need to be met for notifying the carrier, the air carrier also needs to be identifiable from the data contained in the ENS filing: MAWB reference number.	
Output (Final situation): The file was registered and MRN has been generated. The person filing and the carrier (where applicable) has been notified. The file obtains the state 'registered'.	

2.1.4.2.4 GET05 – Retrieve relevant ENS information and control recommendation

Retrieve relevant ENS information and control recommendation	GET05
Organisation: National Customs Administration of the Member State of actual first entry and/or presentation	

Input: Registered Arrival notification or Presentation notification
<p>Description:</p> <p>ENS data related to the given journey of the means of transport for which the arrival has been notified is to be retrieved in an automated process.</p> <p>To match ENS data with the means of transport the following data elements are used depending on the mode of transport:</p> <ul style="list-style-type: none"> • Maritime: The IMO-number and the expected date and time of arrival. • Air: The flight number and the expected date and time of arrival or alternatively by a list of MAWB numbers covered by related ENS data • Independently from the mode of transport a list of MRNs allocated to the related ENS. <p>The arrival can only be notified once when the means of transport has arrived at the first port/airport in the EU. The status of the related ENS needs to be in a state which is prior to the arrival of the means of transport (prior to an arrival notification received for the means of transport). The related ENS will obtain the state 'arrived' after this task is executed. If the ENS is not in a correct state it will not be further processed.</p> <p>In case of the split shipments the ENS will obtain the state 'partially arrived'.</p> <p>In case of a Presentation notification the related ENS will be matched by the MRN of the ENS (or the MRN of a partial ENS filing) referred to in the presentation notification. For air and maritime transport the ENS has to be in the state 'arrived' before actions upon presentation can be processed.</p>
<p>Output (Final situation):</p> <p>In case of an arrival notification the ENS obtains the state 'arrived' or 'partially arrived'.</p> <p>In case of Presentation notification the ENS obtains the state 'presented'.</p>

2.1.4.2.5 ANT01 – Notify ENS data is in incorrect state

Notify ENS data is in incorrect state	ANT01
Organisation: National Customs Administration of the Member State of actual first entry	
Input: Retrieved ENS which is in incorrect state	
<p>Description:</p> <p>A notification to the person filing is generated informing that ENS is in incorrect state and cannot obtain the state 'arrived'.</p>	
<p>Output (Final situation):</p> <p>Person filing is notified that ENS in incorrect state and did not obtain the state 'arrived'.</p>	

2.1.4.2.6 GET06 – Issue control decision

Issue control decision	GET06
Organisation: National Customs Administration of Member State of first entry or control	
Input: Received control recommendation from RMS	
<p>Description</p> <p>The Member State of first entry or control decides on the type of control to be performed based on the recommendation received from RMS.</p>	
<p>Output (Final situation):</p> <p>Control decision is issued.</p>	

2.1.4.2.7 GET07 – Notify control decision

Notify control decision	GET07
Organisation: National Customs Administration of the Member State of actual first entry or control	
Input: Control recommendation from RMS or own e-Screening results	
<p>Description:</p> <p>Control decisions for the identified items are notified to the person filing the arrival or presentation notification. In case of arrival this will force the presentation of the selected items to customs in order to make them available for physical controls even when the presentation of those items at this place was originally not foreseen by that person.</p>	

Output (Final situation):

The control decision for items which require a control upon entry is notified to the person filing.

2.1.4.3 Events

2.1.4.3.1 ANE01 – Arrival notification is received

Arrival notification is received	ANE01
Organisation: National Customs Administration of the Member State of actual first entry	
Arrival notification is received.	

2.1.4.3.2 ANE02 – Arrival notification is rejected

Arrival notification is rejected	ANE02
Organisation: National Customs Administration of the Member State of actual first entry	
Arrival notification is rejected.	

2.1.4.3.3 ANE03 – Arrival notification is rejected by the National Customs Administration in Responsible Member State

ENS state not updated	ANE03
Organisation: National Customs Administration of the Member State of actual first entry	
The process ends after the person filing was informed that ENS was in incorrect state.	

2.1.4.3.4 ANE04 – Control decision notified

Control decision notified	ANE04
Organisation: National Customs Administration of the Member State of actual first entry	
Notification to the person filing that notified items have to be made available for control at the first port or airport in the EU. The process ends.	

2.1.4.3.5 ANE05 – No control at the first port or airport required

No control at the first port or airport required	ANE05
Organisation: National Customs Administration of the Member State of actual first entry	
The process ends after the task issue control decision where no immediate control at the first port or airport in the EU was decided.	

2.1.5 HLS005 – Process presentation and controls

Process presentation and controls	HLS008
Organisation: National Customs Administration of Member State of presentation and control	
Input: Received Presentation notification	
Description: The presentation of the goods triggers the controls recommended by the risk analyst of the RMS. Related ENSs to the presented goods are retrieved, the control decisions issued and, where not otherwise decided, the controls are performed and documented.	
Output (Final situation): Goods were presented and in case of an issued control decision also controlled. The sub-process ends.	

2.1.5.1 Business Process Model

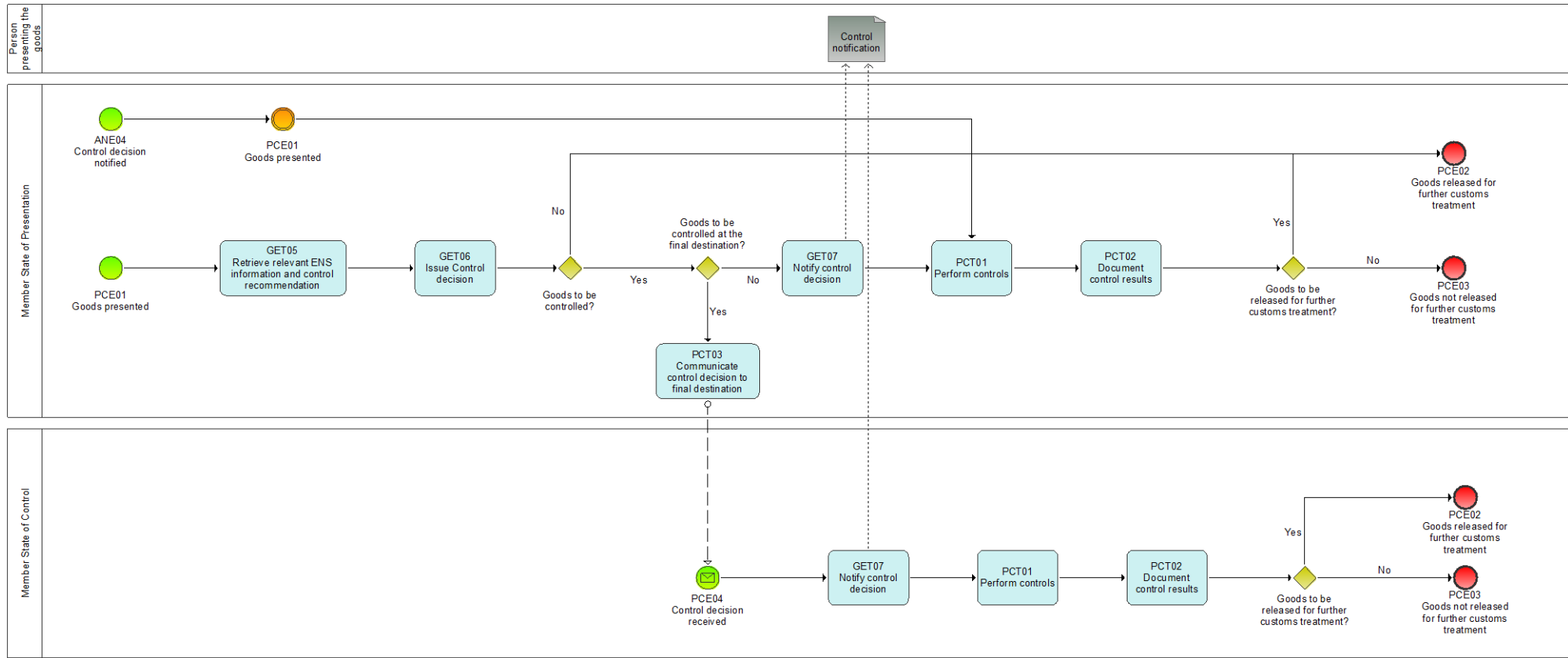

Figure 7: HLS005 Process presentation and controls sub-process

2.1.5.1.1 GET05 – Retrieve relevant ENS information and control recommendation

Retrieve relevant ENS information and control recommendation	GET05
Organisation: National Customs Administration of the Member State of actual first entry and/or presentation	
Input: Registered Arrival notification or Presentation notification	
<p>Description:</p> <p>ENS data related to the given journey of the means of transport for which the arrival has been notified is to be retrieved in an automated process.</p> <p>To match ENS data with the means of transport the following data elements are used depending on the mode of transport:</p> <ul style="list-style-type: none"> • Maritime: The IMO-number and the expected date and time of arrival. • Air: The flight number and the expected date and time of arrival or alternatively by a list of MAWB numbers covered by related ENS data • Independently from the mode of transport a list of MRNs allocated to the related ENS. <p>The arrival can only be notified once when the means of transport has arrived at the first port/airport in the EU. The status of the related ENS needs to be in a state which is prior to the arrival of the means of transport (prior to an arrival notification received for the means of transport). The related ENS will obtain the state 'arrived' after this task is executed. If the ENS is not in a correct state it will not be further processed.</p> <p>In case of the split shipments the ENS will obtain the state 'partially arrived'.</p> <p>In case of a Presentation notification the related ENS will be matched by the MRN of the ENS (or the MRN of a partial ENS filing) referred to in the presentation notification. For air and maritime transport the ENS has to be in the state 'arrived' before actions upon presentation can be processed.</p>	
<p>Output (Final situation):</p> <p>In case of an arrival notification the ENS obtains the state 'arrived' or 'partially arrived'.</p> <p>In case of Presentation notification the ENS obtains the state 'presented'.</p>	

2.1.5.1.2 GET06 – Issue control decision

Issue control decision	GET06
Organisation: National Customs Administration of Member State of first entry or control	
Input: Received control recommendation from RMS	
<p>Description</p> <p>The Member State of first entry or control decides on the type of control to be performed based on the recommendation received from RMS.</p>	
<p>Output (Final situation):</p> <p>Control decision is issued.</p>	

2.1.5.1.3 GET07 – Notify control decision

Notify control decision	GET07
Organisation: National Customs Administration of the Member State of actual first entry or control	
Input: Control recommendation from RMS or own e-Screening results	
<p>Description:</p> <p>Control decisions for the identified items are notified to the person filing the arrival or presentation notification. In case of arrival this will force the presentation of the selected items to customs in order to make them available for physical controls even when the presentation of those items at this place was originally not foreseen by that person.</p>	
<p>Output (Final situation):</p> <p>The control decision for items which require a control upon entry is notified to the person filing.</p>	

2.1.5.1.4 PCT01 – Perform controls

Perform controls	PCT01
-------------------------	--------------

Organisation: National Customs Administration of the Member State of presentation or control
Input: Issued control decision
Description: Controls are performed as decided in task GET06.
Output (Final situation): The controls were performed as decided.

2.1.5.1.5 PCT02 – Document control results

Document control results	PCT02
Organisation: National Customs Administration of the Member State of presentation or control	
Input: Control results	
Description: The results of the performed controls are documented.	
Output (Final situation): The control results are documented.	

2.1.5.1.6 PCT03 – Communicate control decision to final destination

Communicate control decision to final destination	PCT03
Organisation: National Customs Administration of the Member State of control	
Input: Issued control decision	
Description: The control decision is communicated to the Member State of control when different from the Member State where the goods were presented first after their entry into the customs territory of the European Union. This provides the opportunity to perform the controls at the most appropriate place and not necessarily at the border customs office.	
Output (Final situation): The issued control decision was communicated to the Member State of final destination.	

2.1.5.2 Events

2.1.5.2.1 ANE04 – Control decision notified

Control decision notified	ANE04
Organisation: National Customs Administration of the Member State of actual first entry	
Notification to the person filing that notified items have to be made available for control at the first port or airport in the EU. The process ends.	

2.1.5.2.2 PCE01 – Goods presented

Goods presented	PCE01
Organisation: National Customs Administration of the Member State of presentation	
Goods are presented.	

2.1.5.2.3 PCE02 – Goods released for further customs treatment

Goods released for further customs treatment	PCE02
Organisation: National Customs Administration of the Member State of presentation or control	
Goods are released for further customs treatment. The sub-process ends.	

2.1.5.2.4 PCE03 – Goods not released for further customs treatment

Goods not released for further customs treatment	PCE03
Organisation: National Customs Administration of the Member State of presentation or control	

Goods are not released for further customs treatment. The sub-process ends.

2.1.5.2.5 PCE04 – Control decision received

Control decision received	PCE04
Organisation: National Customs Administration of the Member State of control	
Control decision from Member State of presentation was received by the Member State of control (at final destination).	

2.1.6 HLS006 – Amend filing

Amend filing	HLS006
Organisation: National Customs Administration of Responsible Member State	
Input: Amendment of ENS filing	
Description: An original ENS filing can be amended by an amendment filing which refers to the original filing by its MRN.	
Output (Final situation): The ENS filing is amended and processed again with the amended data depending on the lifecycle of the original ENS. The sub-process ends.	

2.1.6.1 Business Process Model

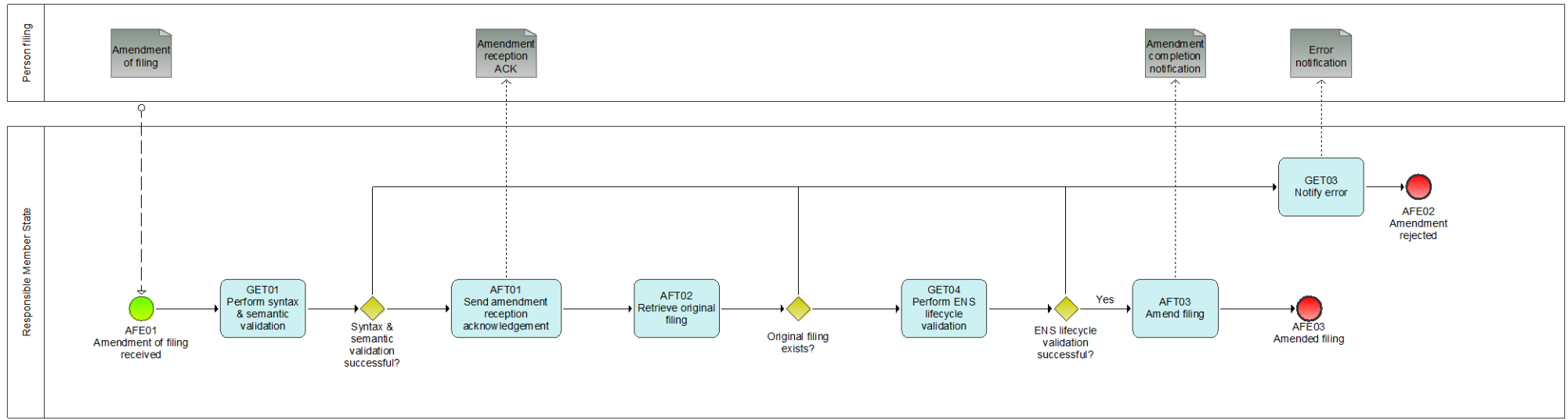

Figure 8: HLS006 Amend filing sub-process

2.1.6.2 Tasks

2.1.6.2.1 GET01 – Perform syntax and semantic validation

Perform syntax and semantic validation	GET01
Organisation: National Customs Administration of Responsible Member State	
Input: ENS filing, Arrival notification, Amendment of ENS filing, Invalidation request	
Description: The input file is validated in an automated process. The validation comprises validation of message syntax, checks of the compliance with business rules and conditions as well as reference data. If the input file is not valid it is rejected; If the input file is valid it is further processed.	
Output (Final situation): The validation will have the following possible outcomes: <ul style="list-style-type: none"> - Successful; - Unsuccessful, in which case <ul style="list-style-type: none"> o the error description will be generated o the input file will obtain the state 'rejected' 	

2.1.6.2.2 AFT01 – Send amendment reception acknowledgement

Send amendment reception acknowledgement	AFT01
Organisation: National Customs Administration of Responsible Member State	
Input: Amendment of ENS filing	
Description: A notification is generated and sent to the person filing. This informs about successful syntax and semantic validation.	
Output (Final situation): The person filing the amendment is notified that its amendment passed syntax and semantic validation successfully.	

2.1.6.2.3 AFT02 – Retrieve original filing

Retrieve original filing	AFT02
Organisation: National Customs Administration of Responsible Member State	
Input: Amendment of ENS filing	
Description: The original filing related to the amendment is to be retrieved. When the original filing can be retrieved and the person filing is authorised to amend that filing the sub-process continues. Else the amendment is rejected.	
Output (Final situation): The original filing was retrieved and it is determined whether the person filing the amendment is authorised to amend the original filing.	

2.1.6.2.4 GET04 – Perform ENS-lifecycle validation

Perform ENS lifecycle validation	GET04
Organisation: National Customs Administration of Responsible Member State	
Input: ENS filing, Amendment of ENS filing, or Invalidation request	
Description The ENS lifecycle validation checks <ul style="list-style-type: none"> • Whether the ENS filing is in the correct state regarding the ENS lifecycle's sequence of the process (E.g. whether an ENS filing refers to a journey of a means of transport which arrived already in the 	

past, or the goods covered by the ENS filing were already presented to the customs and effectively the ENS cannot be filed for the same goods already presented, or ENS cannot be amended or invalidated) and;

- Whether relevant key data; in particular data elements which are used as a unique linking key are unique. In the case of indicated split shipments (i.e. ENS filing containing defined split shipment code indicator) where unique linking key data can be re-used for the remaining goods after the shipment was split, the ENS filing will be processed.

For an ENS amendment;

- That the state of the original ENS filing is not 'presented' or at a state where, for example amendment of the ENS filing is not possible anymore (i.e. customs decided to perform controls, or trader notified by the customs that goods are to be controlled).
- That no particulars were amended which are not allowed to be amended.
- The person filing the amendment needs to be the declarant (D.Es. 3/17, 3/18) of the ENS filing referred to.

For an invalidation request;

- The related ENS filing is required to be in a state prior to the state 'presented'.
- The person filing the invalidation request needs to be the declarant (D.Es. 3/17, 3/18) of the ENS filing referred to.

If the ENS lifecycle validation is successful, the input file obtains the state 'accepted' and the sub-process continues.

If the ENS lifecycle validation fails the input file obtains the state 'rejected' and the sub-process ends.

Output (Final situation):

The state of the input file will either be changed to 'accepted' or 'rejected'.

GET03 – Notify error

Notify error	GET03
Organisation: National Customs Administration of Responsible Member State	
Input: Unsuccessful validation results – containing the error description	
Description: The file is not valid and rejected. The person filing is notified of the rejection and of the errors that caused the rejection.	
Output (Final situation): The notification of error is generated and sent to the person filing and the process ends.	

2.1.6.2.5 AFT03 – Amend filing

Amend filing	AFT03
Organisation: National Customs Administration of Responsible Member State	
Input: Accepted amendment	
Description: The original ENS filing is amended and processed again with the amended data depending on the state of the original ENS. The risk analysis will be re-performed with the amended data.	
Output (Final situation): The original ENS filing is amended.	

2.1.6.3 Events

2.1.6.3.1 AFE01 – Invalidation request received

Amendment of filing received	AFE01
Organisation: National Customs Administration of a Responsible Member State	
An amendment of an original ENS filing is received.	

2.1.6.3.2 AFE02 – Amendment rejected

Amendment rejected	AFE02
Organisation: National Customs Administration of Responsible Member State	
Amendment is rejected. The sub-process ends.	

2.1.6.3.3 AFE03 – Filing amended

Filing amended	AFE03
Organisation: National Customs Administration of Responsible Member State	
The original ENS filing was amended. The sub-process ends.	

2.1.7 HLS007 – Invalidate filing

Invalidate filing	HLS007
Organisation: National Customs Administration of Responsible Member State	
Input: Accepted invalidation request file or 200 days timer expiry.	
Description: The ENS filing for which the 200 days timer expired or the ENS filing referred to in the invalidation request will be invalidated by assigning the status 'invalidated'.	
Output (Final situation): The ENS filing is no longer processed and will be deleted (moved to an archive). The sub-process ends.	

2.1.7.1 Business Process Model

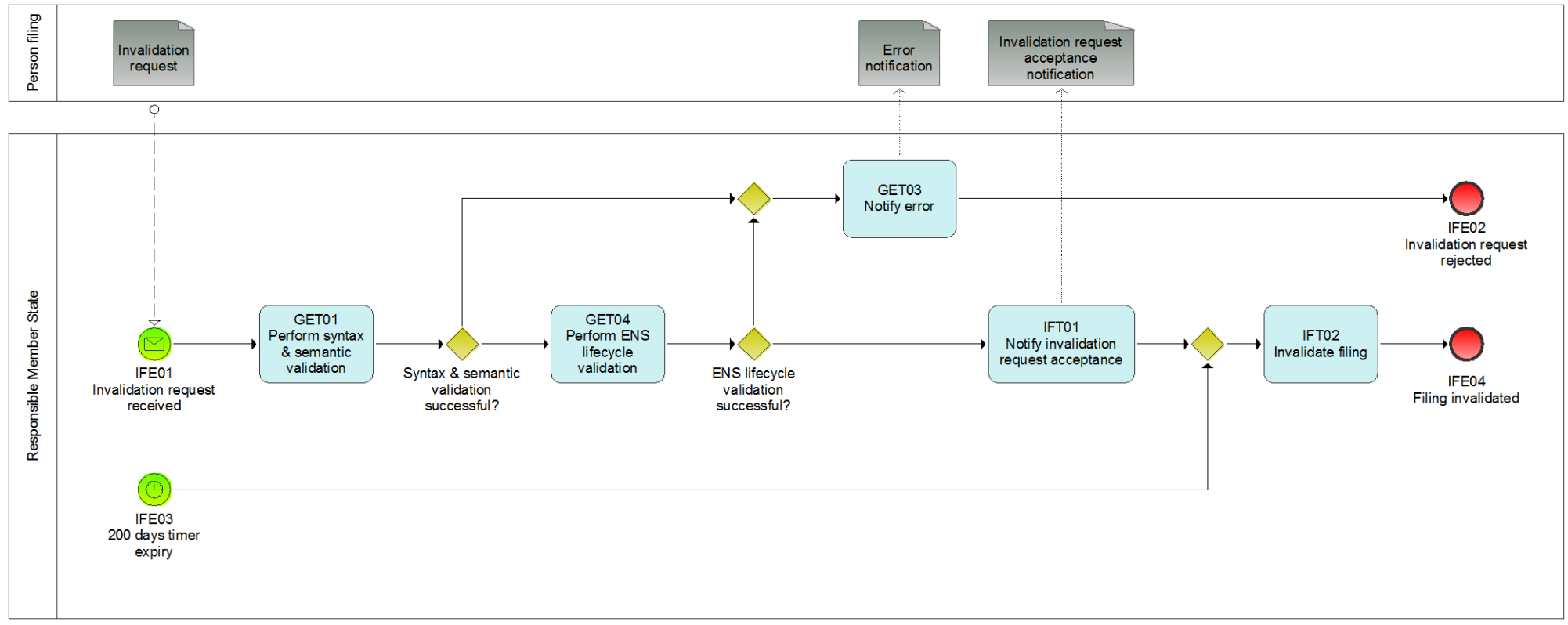

Figure 9: HLS007 Invalidate filing sub-process

2.1.7.2 Tasks

2.1.7.2.1 GET01 – Perform syntax and semantic validation

Perform syntax and semantic validation	GET01
Organisation: National Customs Administration of Responsible Member State	
Input: ENS filing, Arrival notification, Amendment of ENS filing, Invalidation request	
Description: The input file is validated in an automated process. The validation comprises validation of message syntax, checks of the compliance with business rules and conditions as well as reference data. If the input file is not valid it is rejected; If the input file is valid it is further processed.	
Output (Final situation): The validation will have the following possible outcomes: <ul style="list-style-type: none"> - Successful; - Unsuccessful, in which case <ul style="list-style-type: none"> o the error description will be generated o the input file will obtain the state 'rejected' 	

2.1.7.2.2 GET03 – Notify error

Notify error	GET03
Organisation: National Customs Administration of Responsible Member State	
Input: Unsuccessful validation results – containing the error description	
Description: The file is not valid and rejected. The person filing is notified of the rejection and of the errors that caused the rejection.	
Output (Final situation): The notification of error is generated and sent to the person filing and the process ends.	

2.1.7.2.3 GET04 – Perform ENS-lifecycle validation

Perform ENS lifecycle validation	GET04
Organisation: National Customs Administration of Responsible Member State	
Input: ENS filing, Amendment of ENS filing, or Invalidation request	
Description The ENS lifecycle validation checks <ul style="list-style-type: none"> • Whether the ENS filing is in the correct state regarding the ENS lifecycle's sequence of the process (E.g. whether an ENS filing refers to a journey of a means of transport which arrived already in the past, or the goods covered by the ENS filing were already presented to the customs and effectively the ENS cannot be filed for the same goods already presented, or ENS cannot be amended or invalidated) and; • Whether relevant key data; in particular data elements which are used as a unique linking key are unique. In the case of indicated split shipments (i.e. ENS filing containing defined split shipment code indicator) where unique linking key data can be re-used for the remaining goods after the shipment was split, the ENS filing will be processed. For an ENS amendment; <ul style="list-style-type: none"> • That the state of the original ENS filing is not 'presented' or at a state where, for example amendment of the ENS filing is not possible anymore (i.e. customs decided to perform controls, or trader notified by the customs that goods are to be controlled). • That no particulars were amended which are not allowed to be amended. • The person filing the amendment needs to be the declarant (D.Es. 3/17, 3/18) of the ENS filing referred to. For an invalidation request;	

- The related ENS filing is required to be in a state prior to the state 'presented'.
- The person filing the invalidation request needs to be the declarant (D.Es. 3/17, 3/18) of the ENS filing referred to.

If the ENS lifecycle validation is successful, the input file obtains the state 'accepted' and the sub-process continues.

If the ENS lifecycle validation fails the input file obtains the state 'rejected' and the sub-process ends.

Output (Final situation):

The state of the input file will either be changed to 'accepted' or 'rejected'.

2.1.7.2.4 IFT01 – Notify invalidation request acceptance

Notify invalidation request acceptance	IFT01
Organisation: National Customs Administration of Responsible Member State	
Input: Invalidation request	
Description: Notification of acceptance of the invalidation request is generated and sent to the person filing and the process continues.	
Output (Final situation): The person filing is notified of the acceptance of the invalidation request.	

2.1.7.2.5 IFT02 – Invalidate filing

Invalidate filing	IFT02
Organisation: National Customs Administration of Responsible Member State	
Input: Invalidation request or 200 days timer expiry.	
Description: The ENS filing for which the 200 days timer expired or the ENS filing referred to in the invalidation request will be invalidated by assigning the status 'invalidated'.	
Output (Final situation): The ENS filing is no longer processed and will be deleted (moved to an archive).	

2.1.7.3 Events

2.1.7.3.1 IFE01 – Invalidation request received

Invalidation request received	IFE01
Organisation: National Customs Administration of a Responsible Member State	
An invalidation request is received.	

2.1.7.3.2 IFE02 – Invalidation request is rejected

Invalidation request is rejected	IFE02
Organisation: National Customs Administration of Responsible Member State	
Invalidation request is rejected. The sub-process ends.	

2.1.7.3.3 IFE03 – 200 days timer expiry

200 days timer expiry	IFE03
Organisation: National Customs Administration of a Responsible Member State	
The 200 days timer which was started after registration of ENS filing has expired.	

2.1.7.3.4 IFE04 – Filing invalidated

Filing invalidated	IFE04
Organisation: National Customs Administration of Responsible Member State	
The filing was invalidated. The sub-process ends.	

2.2 Events

2.2.1 HLE01 – ENS filing received

ENS filing received	HLE01
Organisation: National Customs Administration of the Responsible Member State	
A person filing lodges an ENS filing.	

2.2.2 HLE02 – Amendment of ENS filing received

Amendment of ENS filing received	HLE02
Organisation: National Customs Administration of the Responsible Member State	
A person filing lodges an amendment for an already lodged ENS filing.	

2.2.3 HLE03 – Invalidation request received

Invalidation request received	HLE03
Organisation: National Customs Administration of a Responsible Member State	
An invalidation request is received.	

2.2.4 HLE04 – 200 days timer expiry

200 days timer expiry	HLE04
Organisation: National Customs Administration of a Responsible Member State	
The 200 days timer which was started after registration of the ENS filing has expired.	

2.2.5 HLE05 – ENS filing invalidated

ENS filing invalidated	HLE05
Organisation: National Customs Administration of Responsible Member State	
The filing was invalidated. The process ends.	

2.2.6 HLE06 – Entry process completed

Entry process completed	HLE06
Organisation: National Customs Administration of the Responsible Member State	
The entire entry process is completed.	

2.2.7 HLE07 – Arrival notification received

Arrival notification received	HLE07
Organisation: National Customs Administration of the Member State of actual first entry	
Arrival notification is received.	

2.2.8 HLE08 – Arrival notification processed

Arrival notification processed	HLE08
Organisation: National Customs Administration of the Member State of actual first entry	

Arrival notification was processed.

2.2.9 HLE09 – Goods presented

Goods presented	HLE09
Organisation: National Customs Administration of the Member State of presentation	
The person presenting the goods presents the goods to the Member State of control.	

2.2.10 HLE10 – Goods presented and controlled

Goods presented and controlled	HLE10
Organisation: National Customs Administration of the Member State of presentation and/or control	
Control of goods was performed and control results were documented.	

3 MAIN ENTITIES & STATE TRANSITIONS

The ICS2 comprises several entities which interact with each other through the different ICS2 sub-processes. In this chapter, the entities with the most significant role in the process of entry of goods will be introduced and described.

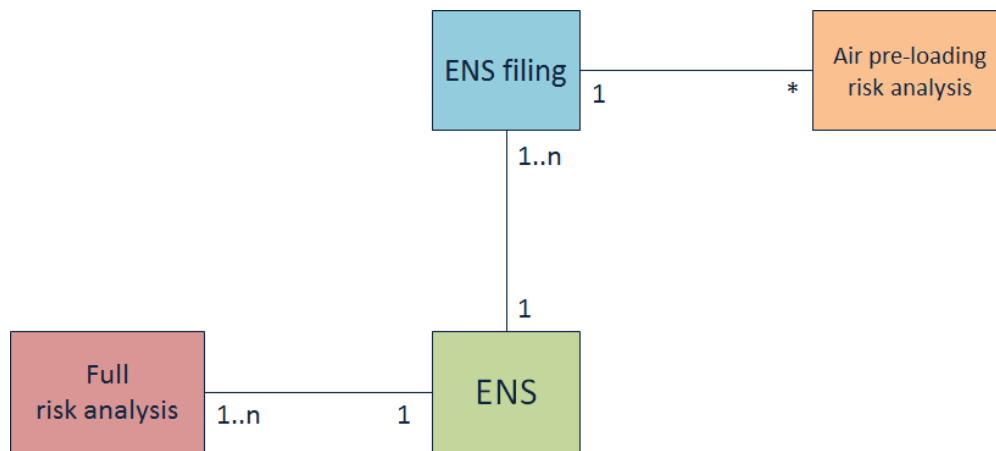

Figure 10: Main entities

An ENS is constructed with either single or multiple ENS filing(s).

The ENS filings that contain one or more PLACI dataset(s) will have a pre-loading risk analysis performed on each of those datasets.

When an ENS is considered complete, meaning that all expected ENS filings have been received from the different involved parties, a full risk analysis will be performed on that ENS. There might be more than one full risk analysis performed on an ENS, in the case of parts of the ENS were amended.

3.1 State transition diagram

This diagram (Figure 12) presents the state transitions that each of the aforementioned main ICS2 entities can go through. The Figure 11 explains the notation used in the state transitions diagram.

For the facilitation of the reader, the sub-processes and the specific events and tasks that might trigger a state change in any of the entities are also depicted. The sub-processes, tasks and events that are referenced here are described in Chapter **Fout! Verwijzingsbron niet gevonden..**

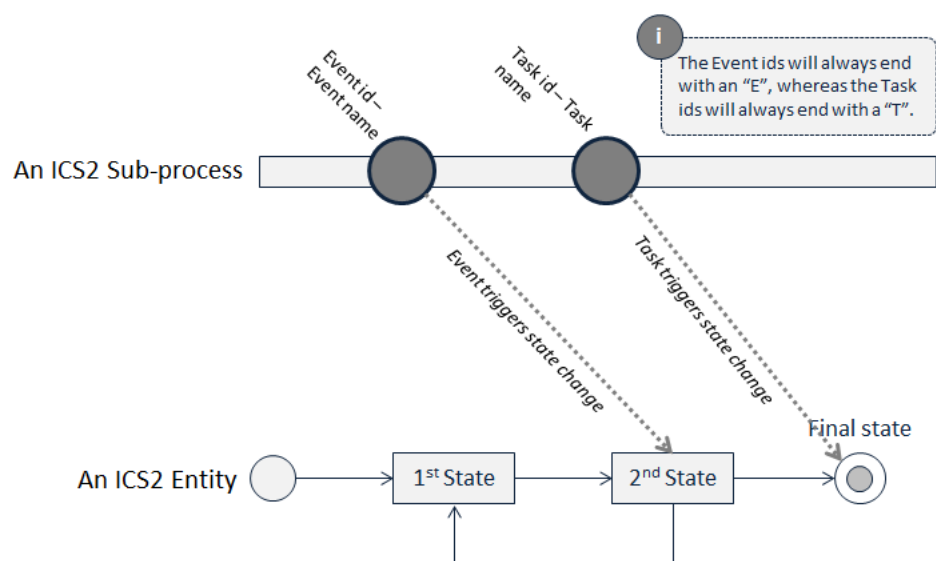

Figure 11: State transition example

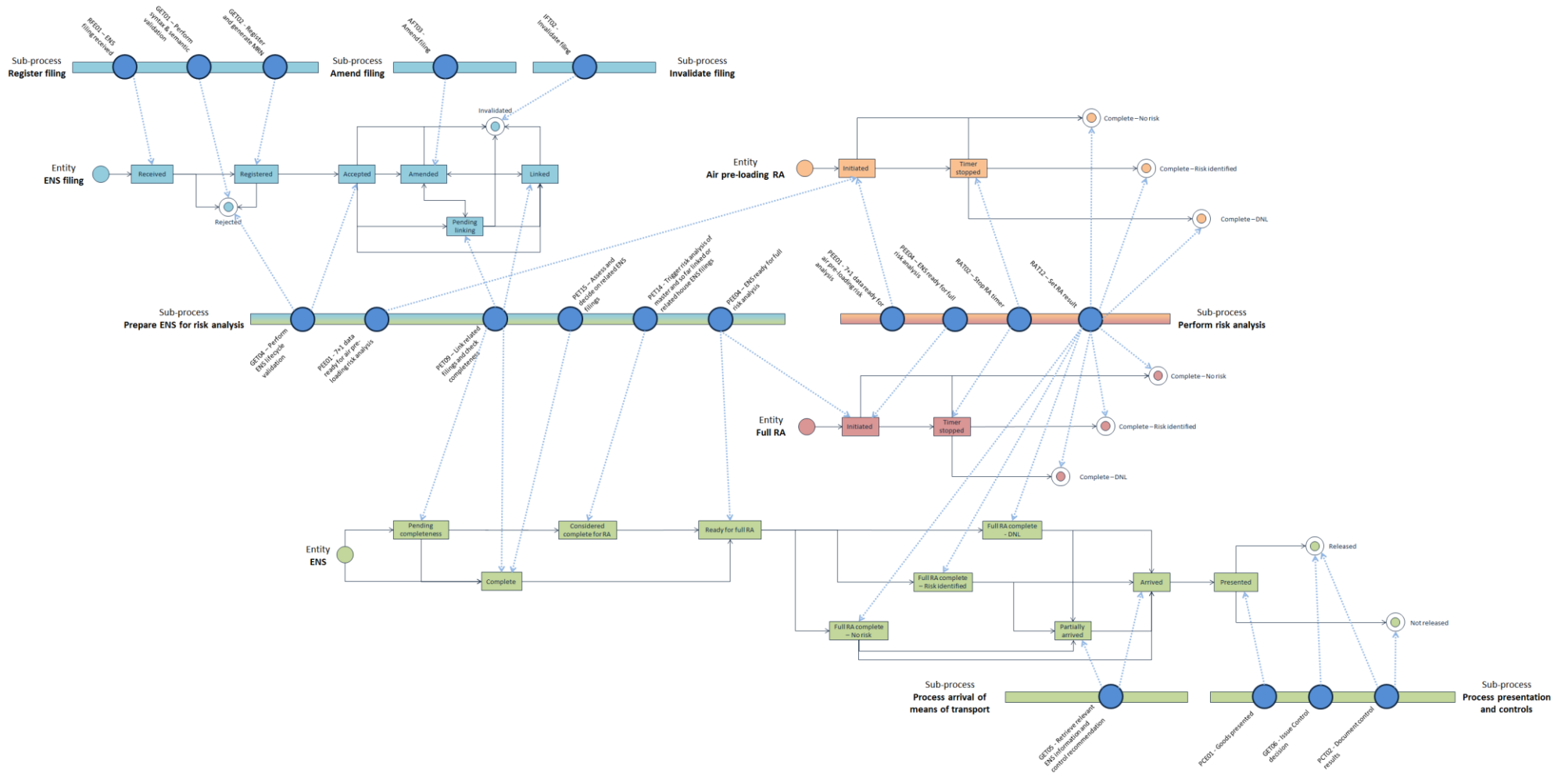

Figure 12: State transition diagram

4 ANNEX

4.1 ENS filing types

F10	Sea and inland waterways – Complete dataset – Straight bill of lading containing the necessary information from consignee	F1a = F1b+F1d
F11	Sea and inland waterways – Complete dataset – Master bill of lading with underlying house bill(s) of lading containing the necessary information from consignee at the level of the lowest house bill of lading	F1a = F1b + F1c + F1d
F12	Sea and inland waterways – Partial dataset – Master bill of lading only	F1b
F13	Sea and inland waterways – Partial dataset – Straight bill of lading only	F1b
F14	Sea and inland waterways – Partial dataset – House bill of lading only	F1c
F15	Sea and inland waterways – Partial dataset – House bill of lading with the necessary information from consignee	F1c + F1d
F16	Sea and inland waterways – Partial dataset – Necessary information required to be provided by consignee at the lowest level of transport contract (straight bill or the lowest house bill of lading)	F1d
F20	Air cargo (general) – Complete dataset lodged pre-loading	F2a
F21	Air cargo (general) – Partial dataset – Master air waybill lodged pre-arrival	F2b
F22	Air cargo (general) – Partial dataset – House air waybill lodged pre-arrival	F2c
F23	Air cargo (general) – Partial dataset – Minimum dataset lodged pre- loading in accordance with Article 106(1) second subparagraph of Delegated Regulation (EU) 2015/2446 without master air waybill reference number	Part of F2d
F24	Air cargo (general) – Partial dataset – Minimum dataset lodged pre- loading in accordance with Article 106(1) second subparagraph of Delegated Regulation (EU) 2015/2446 with master air waybill reference number	F2d
F25	Air cargo (general) – Partial dataset – Master air waybill reference number lodged pre-loading in accordance with Article 106(1) second subparagraph of Delegated Regulation (EU) 2015/2446	Part of F2d complementing the message with specific circumstance indicator F23
F26	Air cargo (general) – Partial dataset – Minimum dataset lodged pre- loading in accordance with Article 106(1) second subparagraph of Delegated Regulation (EU) 2015/2446 and containing additional house air waybill information	F2c + F2d
F27	Air cargo (general) – Complete dataset lodged pre-arrival	F2a
F28	Air cargo (general) – Complete dataset lodged pre-loading – Direct air waybill	F2a
F29	Air cargo (general) – Complete dataset lodged pre-arrival – Direct air waybill	F2a
F30	Express consignments – Complete dataset lodged pre-arrival in accordance with Article 106(1) second subparagraph of Delegated Regulation (EU) 2015/2446	F3a by air mode
F31	Express consignments – Complete dataset in accordance with the time-limits applicable for the mode of transport concerned	F3a by other than air mode

F32	Express consignments — Partial dataset — Minimum dataset lodged pre-loading in accordance with Article 106(1) second subparagraph of Delegated Regulation (EU) 2015/2446	F3b
F40	Postal consignments — Complete dataset lodged pre-loading in accordance with Article 106(1) second subparagraph of Delegated Regulation (EU) 2015/2446	F4a by air mode
F41	Postal consignments – Complete dataset in accordance with the time-limits applicable for the mode of transport concerned (other than the air)	F4a by other than air mode
F42	Postal consignments – Partial dataset - Master air waybill containing necessary postal air waybill information lodged in accordance with the time-limits applicable for the mode of transport concerned	F4b
F43	Postal consignments — Partial dataset — Minimum dataset lodged pre- loading in accordance with Article 106(1) second subparagraph of Delegated Regulation (EU) 2015/2446	F4c
F44	Postal consignment — Partial dataset — Receptacle identification number lodged pre-loading in accordance with Article 106(1) second subparagraph of Delegated Regulation (EU) 2015/2446	F4d
F50	Road mode of transport	F5
F51	Rail mode of transport	F5

End of document